

# Amphenol

## AC IDC SERIES CABLE ASSEMBLY INSTRUCTIONS

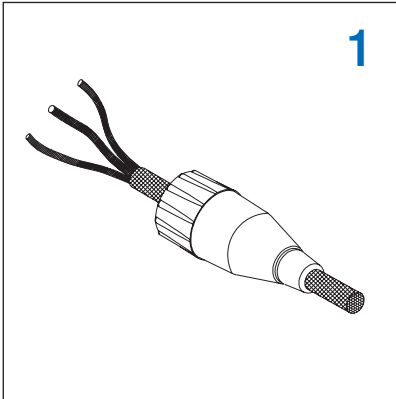

1  
Push the cable through the boot assembly and strip the cable back 35 to 40 mm. Twist the shield wire.

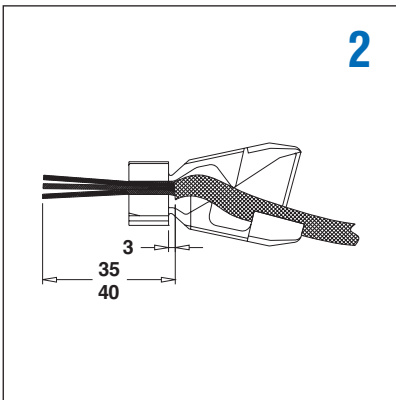

2  
Fit the cable into the 'Jaws' cable clamp ensuring that the cable is pushed up to the neck of the clamp within 3mm.

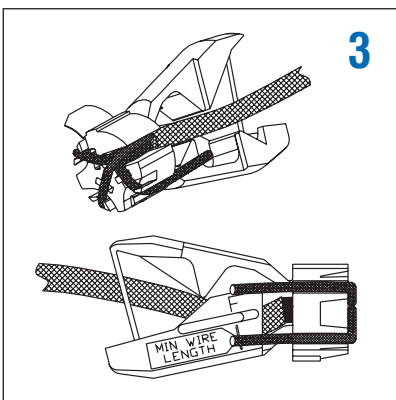

3  
Pull back the conductors into their individual wire guidetracks. Note: Two spring fingers in the clamp will hold the conductors in position during subsequent operations. The ends of the two insulated wires must be on or past the minimum wire length mark.

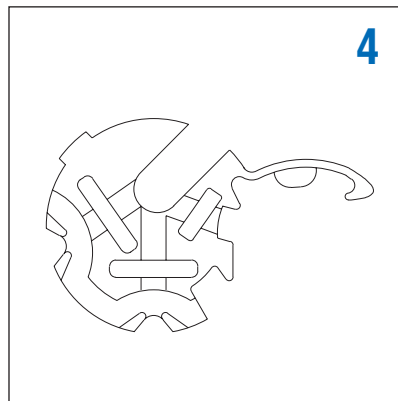

4  
For ground protection the twisted shield wire is clipped in place with the ground protect flap.

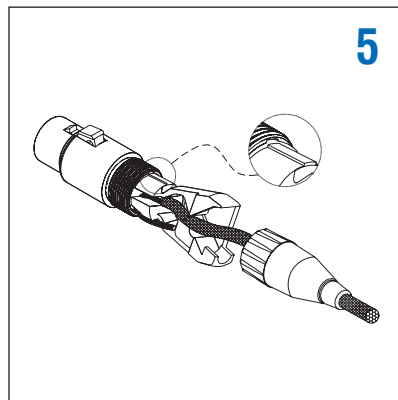

5  
Trim back the shield wire, so there are no wires coming out of the flap and fit the 'Jaws' cable clamp into the shell assembly, ensuring the keyways are aligned.

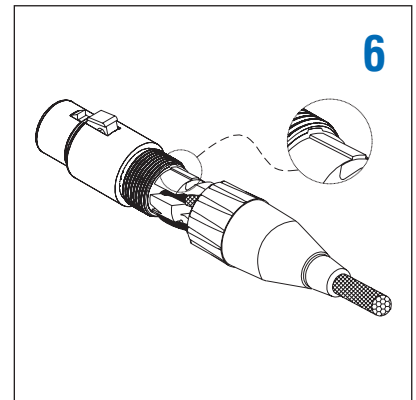

6  
Close the cable clamp slightly and push the boot over the clamp ensuring the wires fit inside the boot.

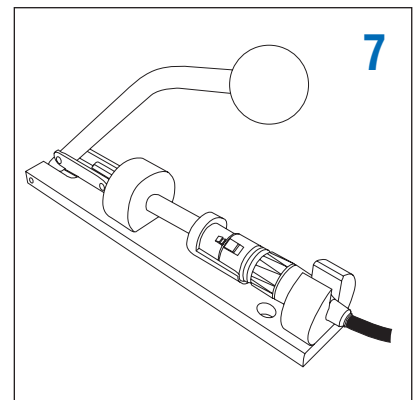

7  
Final assembly can be achieved either by manually screwing the boot on, or by using an Amphenol Australia T2860 termination tool.