

HALF-SECTION

PCB LAYOUT

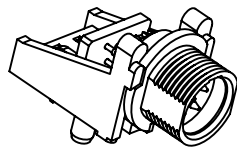

ISO VIEW
(SCALE 1:1)

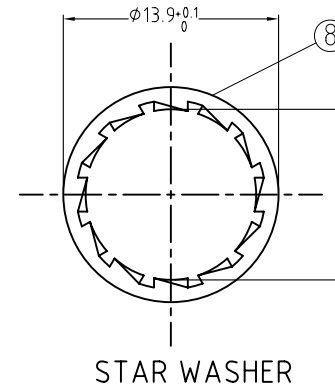
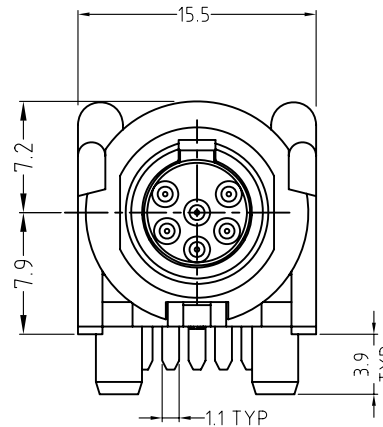
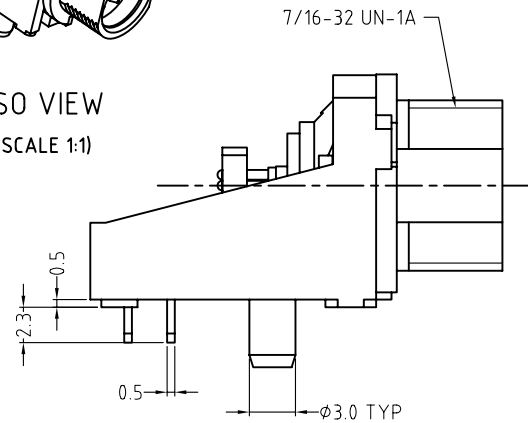

STAR WASHER

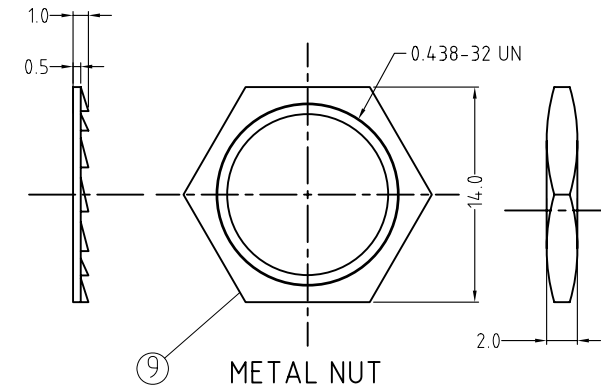

METAL NUT

Specification: Electrical
 Contact Resistance: <0.01 ohm
 Insulation Resistance: >500Megaohm
 Dielectric Strength: 250VDC
 Rated Current: 5A

Mechanical
 Mating: >5000 cycles
 Insertion/withdrawal Force: >10N & <30N.

Notes:
 1. Part must conform to RoHS compliance
 2. Plastic parts conform to UL94 V-0 compliant.

ITEM	MATERIAL	MATERIAL	ITEM
1	CHASSIS	PA+30%GF/BLACK, UL 94 V-0	1
2	CONTACTS	BRASS-GOLD PLATED	6
3	PCB	PRINTED CIRCUIT BOARD	1
4	INSULATOR	PPS/BLACK, UL 94 V-0	1
5	HOUSING	C3604/NICKEL PLATED	1
6	CONTACT	BRASS/GOLD PLATED	6
7	CONTACT	SUS 301/TIN PLATING	1
8	WASHER	BRASS-NICKEL PLATED	1
9	METAL NUT	BRONZE-NICKEL PLATED	1

UNLESS OTHERWISE SPECIFIED TOLERANCE TO BE		THIS DOCUMENT IS THE PROPERTY OF AMPHENOL AUSTRALIA PTY. LTD.. NO PART THEREOF MAY BE REPRODUCED AND USED WITHOUT THE PRIOR WRITTEN CONSENT OF THE OWNER			
LINEAR	ANGULAR	CAD FILE:	DRN:	DATE:	TITLE:
X ± 0.5	X° ± 1°	55010613003111	M.N.H	04-09-09	MINI XLR 6 PIN MALE
X,X ± 0.1	X°X' ± 30'	MATL: SEE NOTES	CKD: M.H.	DATE: 13-11-09	PANEL MOUNT RA PCB
X,X ± 0.05	X°X'X" ± 15"	FINISH: SEE NOTES	APP'D: M.H.	DATE: 13-11-09	CUSTOMER DRAWING
DO NOT SCALE		SCALE: 2 : 1		PART No: AG6MCC	SIZE: A4
DIMENSIONS IN MILLIMETRES		THRD ANGLE PROJECTION		DRAWING NO. 55010613-003-1	

REV.	CHANGE DETAILS	BY	DATE	CHG/No
1	CHANGE PART NUMBER FROM AG6F-C TO AG6FL	M.H	13-11-09	8868
0	FIRST ISSUE	M.N.H	04-09-09	----

Amphenol
 Amphenol Australia Pty.Ltd, 2 Freeways Blvd, Keysborough, Vic.3173
 DRAWING NO. 55010613-003-1 SHEET 1 OF 1