

LEGEND = KEY PRODUCT CHARACTERISTICS

REVISION HISTORY

REV	DESCRIPTION	DATE	BY	ECN
1	FIRST ISSUE	19/12/19	MH	----

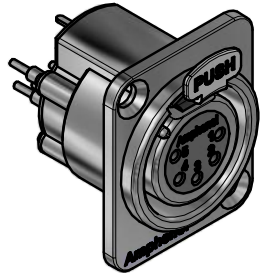

3D VIEW

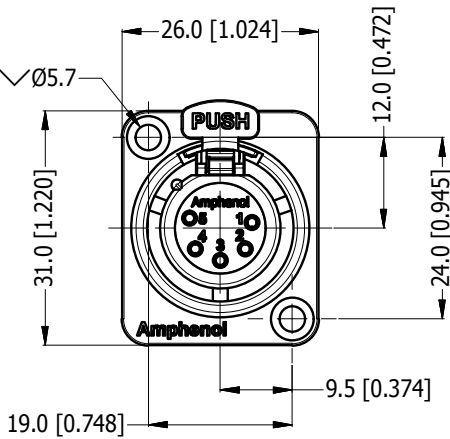

THROUGH HOLE

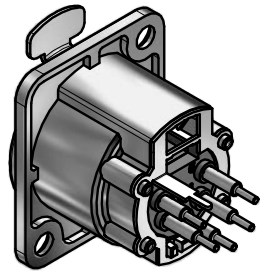
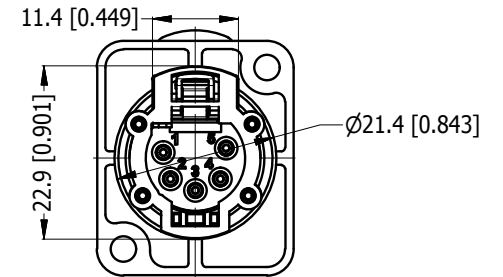
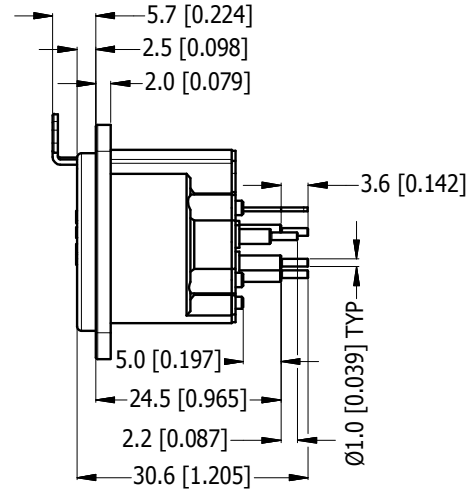

2~M3x0.5 THREAD

M3 THREAD OPTION

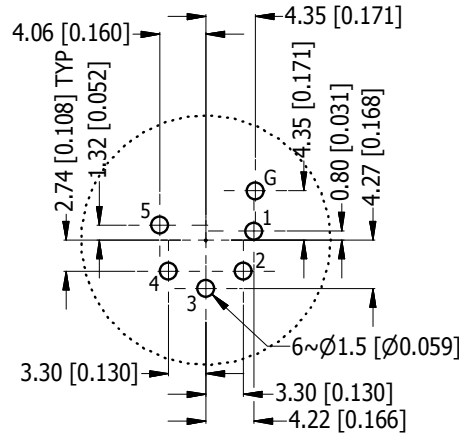
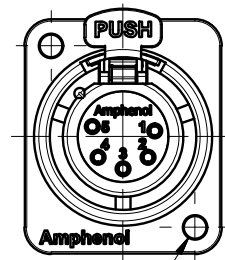

PCB LAYOUT

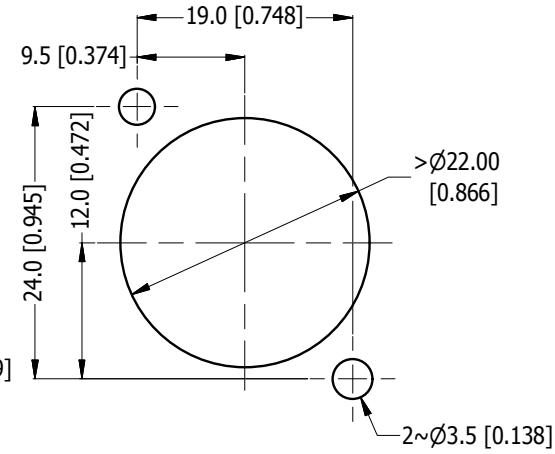

PANEL CUT OUT  
(SCALE 2:1)

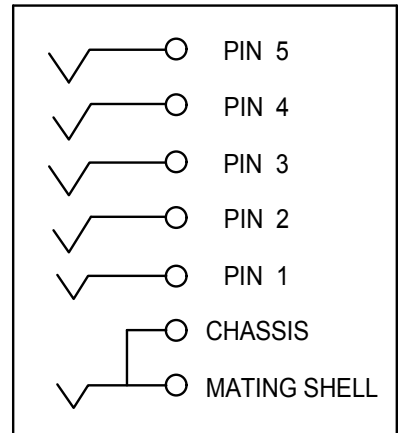

SCHEMATIC CHART

PART NUMBER	SHELL FINISH	PIN CONTACT FINIS
AX5FDV	NICKEL PLATED	TIN PLATED
AX5FDVB	MATT BLACK COATING	TIN PLATED
AX5DV-M3	M3 THREAD - NICKEL PLATED	TIN PLATED
AX5FDVB-M3	M3 THREAD - MATT BLACK COATING	TIN PLATED
AX5FDV-AU	NICKEL PLATED	GOLD PLATED
AX5FDVB-AU	MATT BLACK COATING	GOLD PLATED
AX5FDV-AU-M3	M3 THREAD - NICKEL PLATED	GOLD PLATED
AX5FDVB-AU-M3	M3 THREAD - MATT BLACK COATING	GOLD PLATED

UNLESS OTHERWISE SPECIFIED TOLERANCE TO BE	
LINEAR	ANGULAR
X ± 0.5	X' ± 1
X.X ± 0.2	X.X' ± 30'
X.XX ± 0.1	X.XX" ± 15'

BREAK ALL SHARP EDGES AND REMOVE ALL BURRS

DO NOT SCALE

DIMENSIONS IN MILLIMETRES

THIS DOCUMENT IS THE PROPERTY OF AMPHENOL AUSTRALIA PTY. LTD.  
NO PART THEREOF MAY BE REPRODUCED AND USED  
WITHOUT THE PRIOR WRITTEN CONSENT OF THE OWNER

MATERIAL: **SEE COMPONENT**

FINISH: **SEE COMPONENT**

DRN: M.H	DATE: 19/12/19
CKD: M.H	DATE: 19/12/19
APP'D: P.M	DATE: 19/12/19

SCALE: **1:1** SIZE: **A4**

**Amphenol**

Amphenol Australia Pty.Ltd,  
22 Industry Boulevard, Carrum Downs, VIC 3201

TITLE:  
**AX5FDV  
D-TYPE AX PCB PANEL MOUNT  
CUSTOMER DWG**

PART No.  
**SEE TABLE**

DRAWING No. **55011004-131-2** SHEET **2/2**

CAD FILE 55011004131111