

LEGEND = KEY PRODUCT CHARACTERISTICS

REVISION HISTORY				
REV	DESCRIPTION	DATE	BY	CHG/No
1	FIRST ISSUE	03/05/18	MH	---

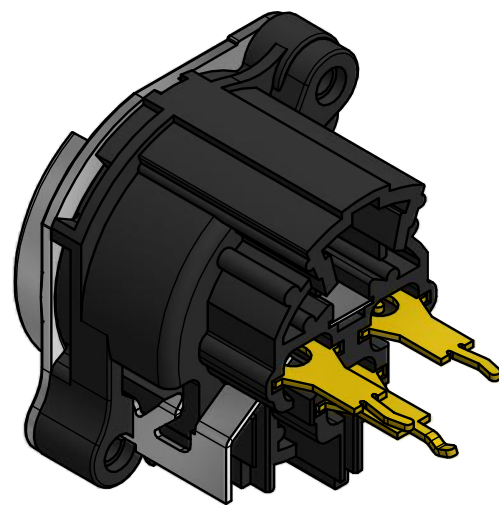

**ISO VIEW**

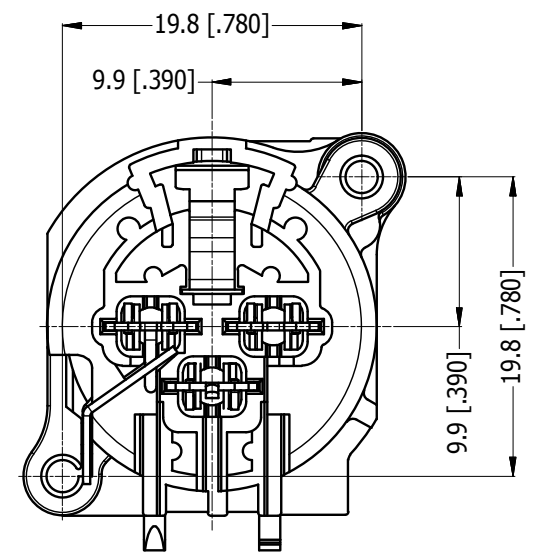
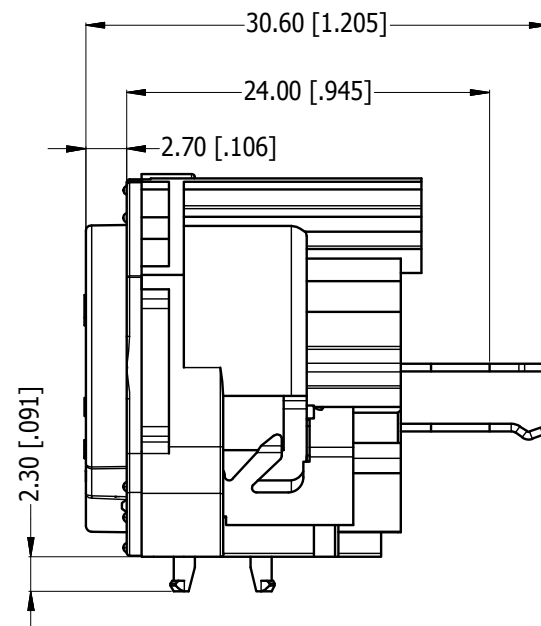
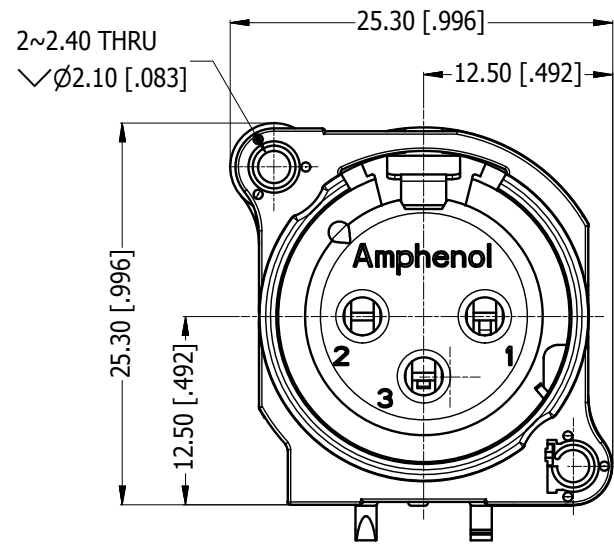
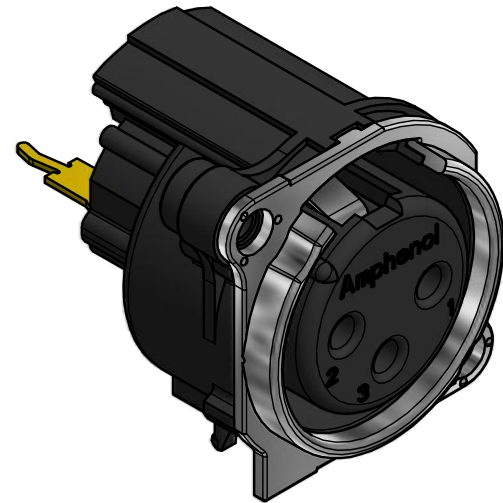
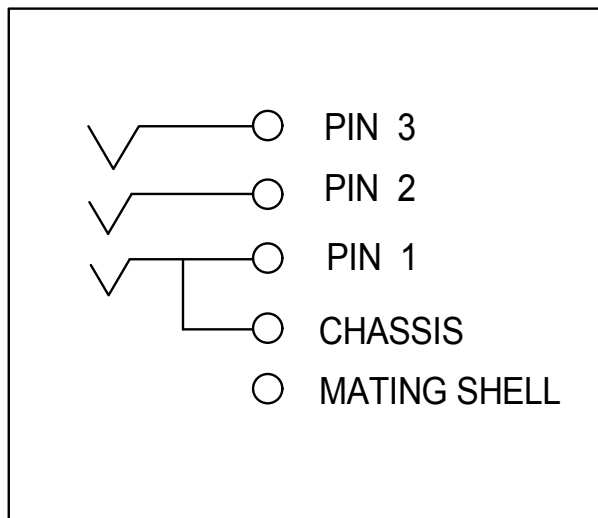

**SCHEMATIC CHART**

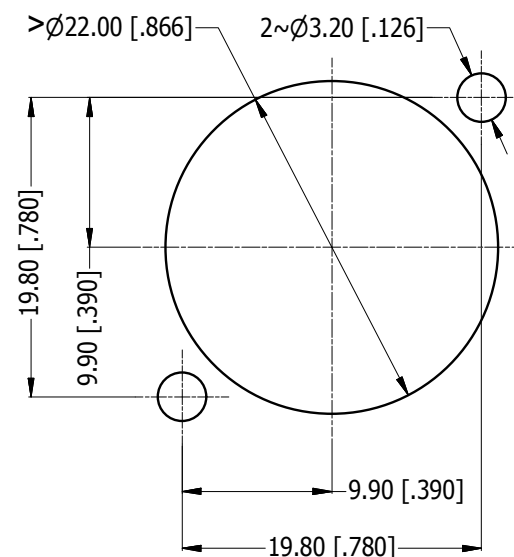

**PANEL CUT OUT  
REAR VIEW**

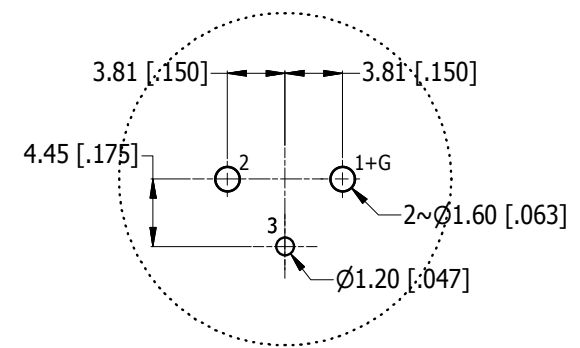

**PCB-LAYOUT  
COMPONENT SIDE  
TOLERANCE:  $\pm 0.05\text{mm} [.002"]$**

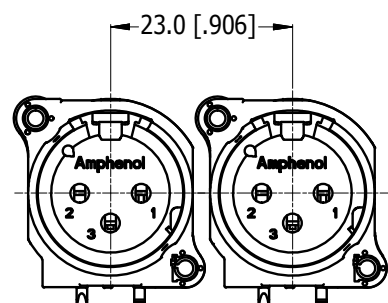

**MIN MOUNTING PITCH  
SCALE 1:1**

PART NUMBER TABLE	
PART NUMBER	METAL FLANGE FINISH
AC3FBVL3-AU-PRE	SATIN NICKEL
AC3FBVBL3-AU-PRE	MATT BLACK

UNLESS OTHERWISE SPECIFIED TOLERANCE TO BE		THIS DOCUMENT IS THE PROPERTY OF AMPHENOL AUSTRALIA PTY. LTD. NO PART THEREOF MAY BE REPRODUCED AND USED WITHOUT THE PRIOR WRITTEN CONSENT OF THE OWNER			
LINEAR	ANGULAR	MATERIAL:	DRN:	DATE:	DATE:
X ± 0.5	X' ± 1	<b>REFER TO COMPONENT</b>	MH	03/05/18	
X.X ± 0.2	X.X' ± 30'		CKD:	M.H	03/05/18
X.XX ± 0.1	X.XX" ± 15'	FINISH:	P.M	03/05/18	
BREAK ALL SHARP EDGES AND REMOVE ALL BURRS		DO NOT SCALE			
DIMENSIONS IN MILLIMETRES		SCALE:	2:1	SIZE:	A3

**Amphenol** Amphenol Australia Pty.Ltd.  
22 Industry Blvd, Carrum Downs, VIC 3201

TITLE: **AC3FBVL3-AU-PRE VERTICAL FEMALE CUSTOMER DRAWING**

PART No: **SEE TABLE**

DRAWING NO. **55011309-000-2** SHEET **2/2**

CAD FILE 55011309000221