

LEGEND = KEY PRODUCT CHARACTERISTICS

REVISION HISTORY				
REV	DESCRIPTION	DATE	BY	CHG/No
0	FIRST ISSUE	17-03-17	MH	---

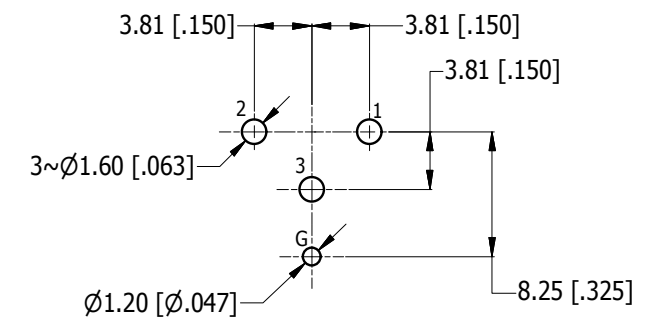
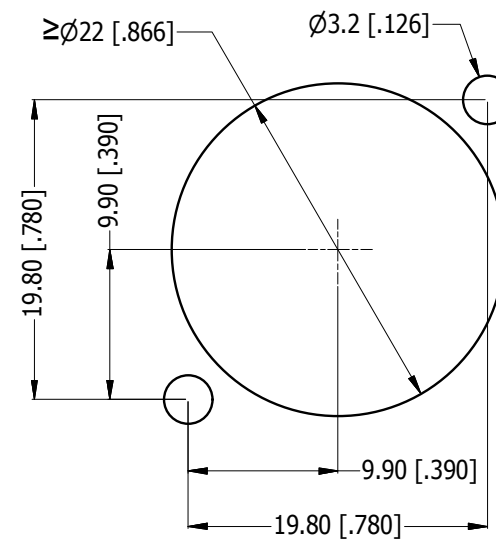
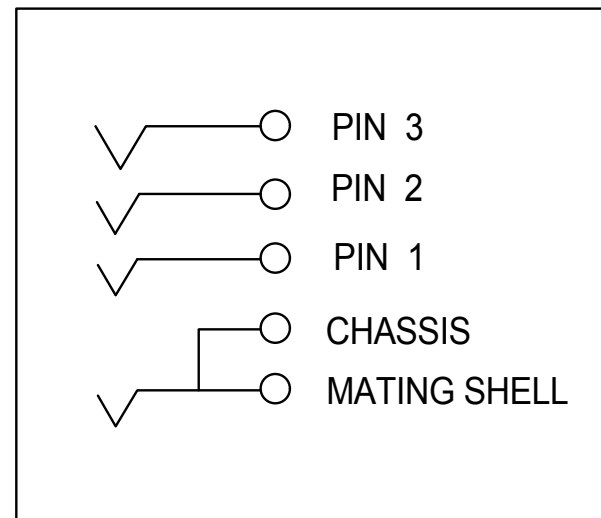
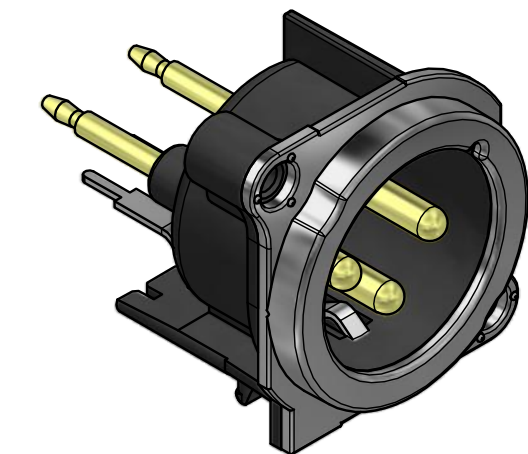
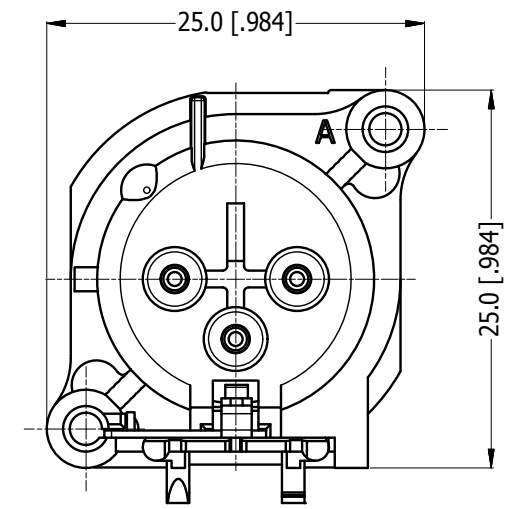
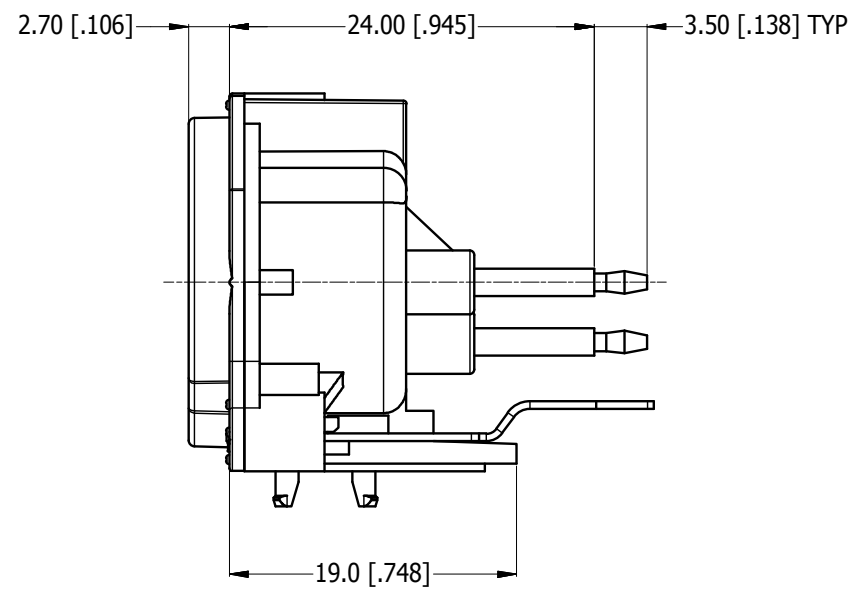
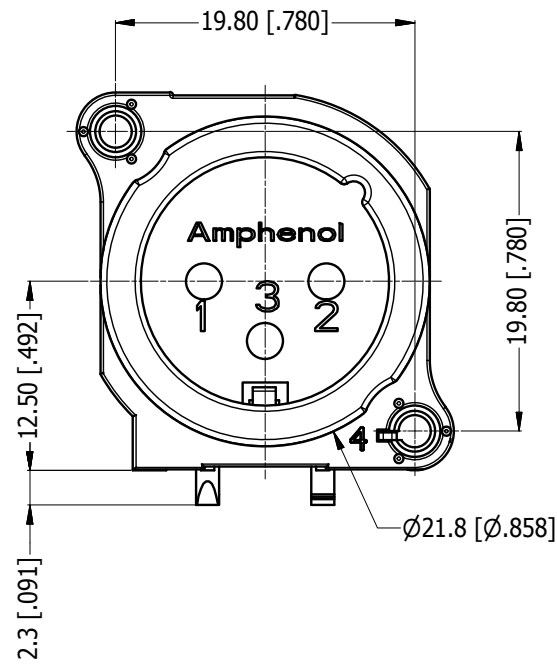
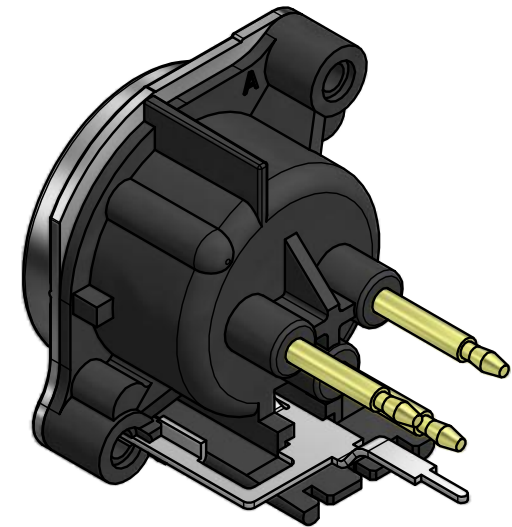

ISO VIEWS

SCHEMATIC CHART

**PANEL CUT OUT
REAR VIEW**

**PCB-LAYOUT
COMPONENT SIDE
TOLERANCE: ± 0.05mm [.002"]**

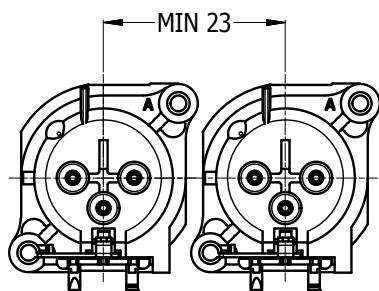

**MIN MOUNTING PITCH
(SCALE 1:1)**

UNLESS OTHERWISE SPECIFIED TOLERANCE TO BE		THIS DOCUMENT IS THE PROPERTY OF AMPHENOL AUSTRALIA PTY. LTD. NO PART THEREOF MAY BE REPRODUCED AND USED WITHOUT THE PRIOR WRITTEN CONSENT OF THE OWNER				Amphenol Amphenol Australia Pty.Ltd, 22 Industry Blvd, Carrum Downs, VIC 3201	
LINEAR	ANGULAR	MATERIAL: REFER TO COMPONENT	DRN: MH	DATE: 17-03-17	TITLE: B-TYPE VERTICAL MALE CUSTOMER DRAWING	PART No: AC3MBV2-AU-PRE	
X ± 0.5	X' ± 1	BREAK ALL SHARP EDGES AND REMOVE ALL BURRS	CKD: M.H	DATE: 17-03-17	DO NOT SCALE	DRAWING NO. 55011230-000-2	SHEET 2/2
X.X ± 0.1	X.X' ± 30'	FINISH: REFER TO COMPONENT	APP'D: P.M	DATE: 17-03-17	DIMENSIONS IN MILLIMETRES		
X.XX ± 0.05	X.XX" ± 15'	THIRD ANGLE PROJECTION		SCALE: 2:1	SIZE: A3	CAD FILE 55011230000220	