

LEGEND = KEY PRODUCT CHARACTERISTICS

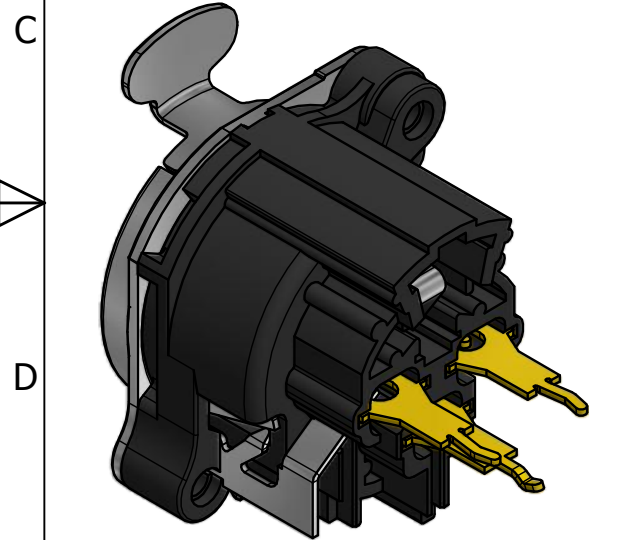

REVISION HISTORY				
REV	DESCRIPTION	DATE	BY	CHG/No
0	FIRST ISSUE	05/02/18	MH	---

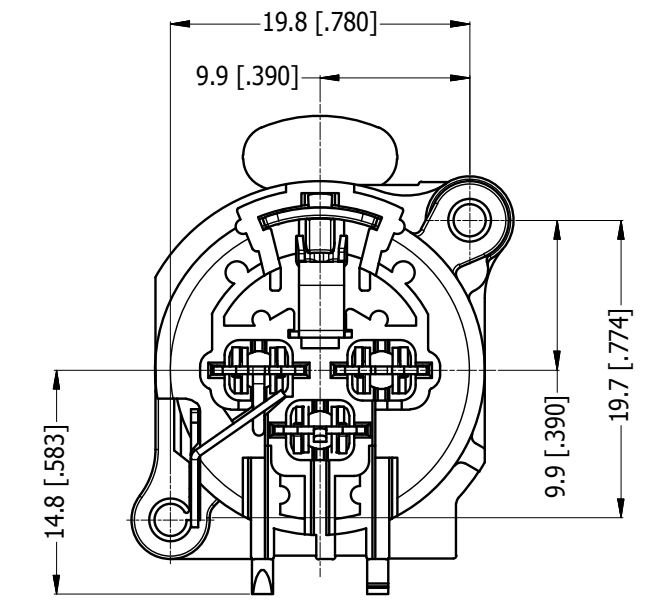
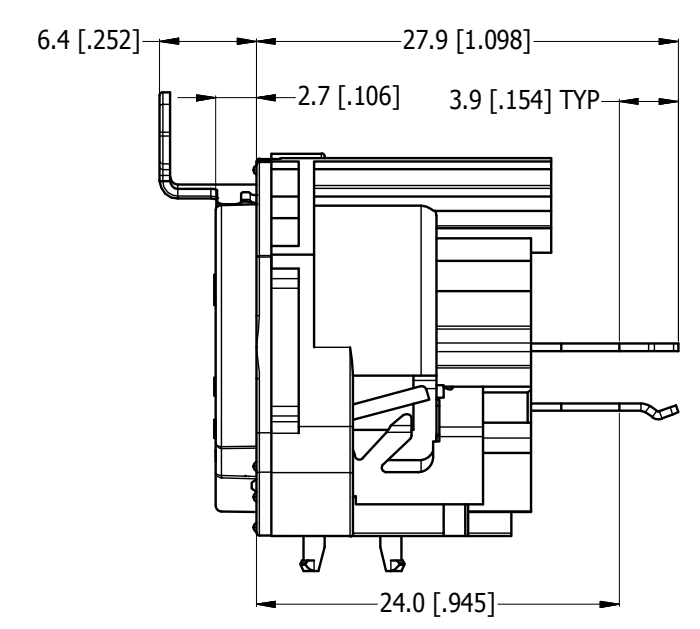
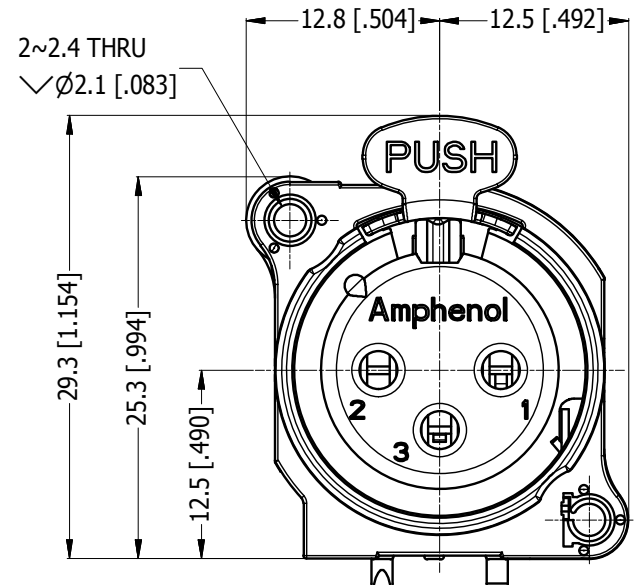
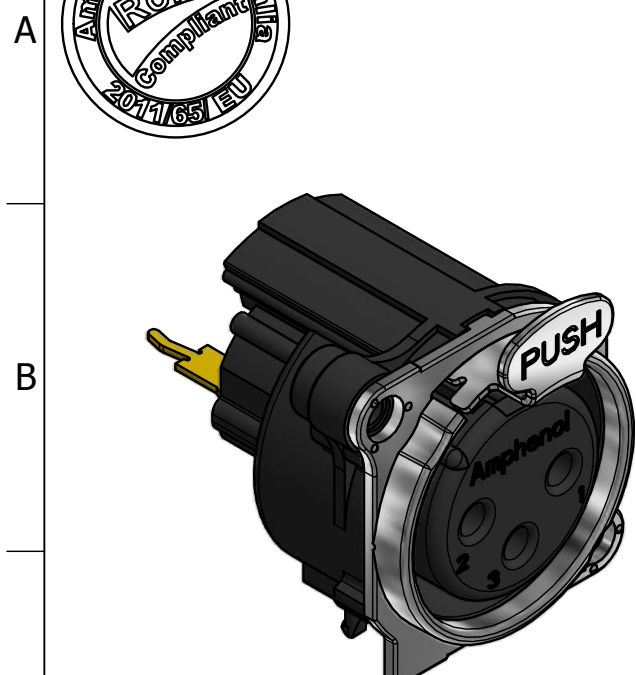

ISO VIEW

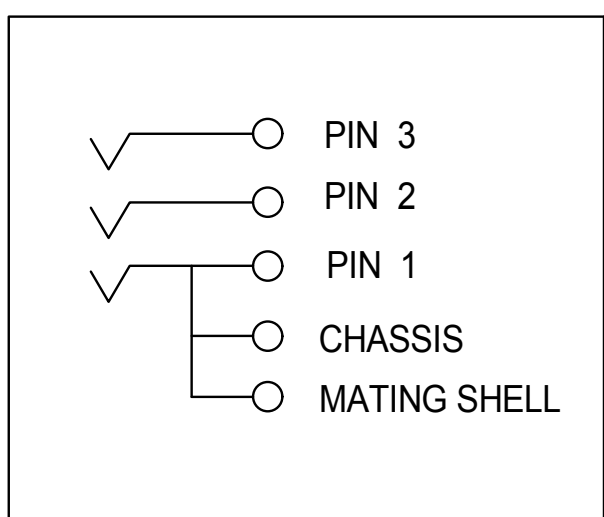

SCHMATIC CHART

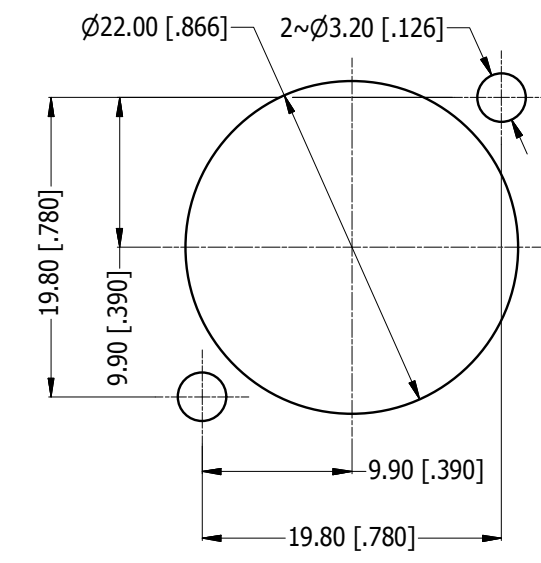

PANEL CUT OUT
REAR VIEW

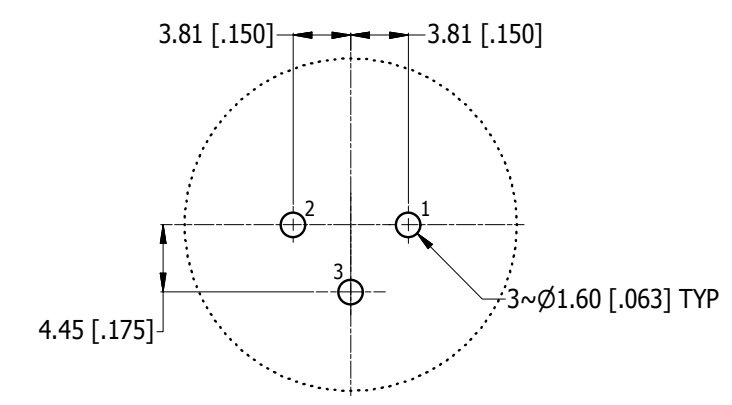

PCB-LAYOUT
COMPONENT SIDE
TOLERANCE: $\pm 0.05\text{mm} [.002"]$

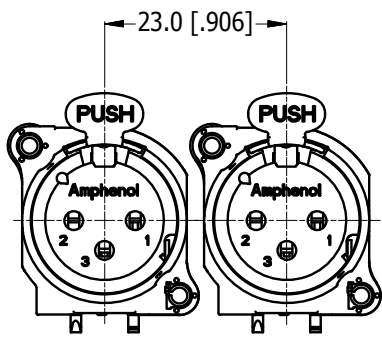

MIN MOUNTING PITCH
SCALE 1:1

PART NUMBER TABLE	
PART NUMBER	METAL FLANGE FINISH
AC3FBV1-AU-PRE	SATIN NICKEL
AC3FBVB1-AU-PRE	MATT BLACK

UNLESS OTHERWISE SPECIFIED TOLERANCE TO BE		THIS DOCUMENT IS THE PROPERTY OF AMPHENOL AUSTRALIA PTY. LTD. NO PART THEREOF MAY BE REPRODUCED AND USED WITHOUT THE PRIOR WRITTEN CONSENT OF THE OWNER			
LINEAR	ANGULAR	MATERIAL:	DRN:	DATE:	DATE:
X ± 0.5	X' ± 1	REFER TO COMPONENT	MH	05/02/18	05/02/18
X.X ± 0.2	X.X' ± 30'	FINISH: REFER TO COMPONENT	CKD:	DATE:	DATE:
X.XX ± 0.1	X.XX' ± 15'		M.H	05/02/18	05/02/18
BREAK ALL SHARP EDGES AND REMOVE ALL BURRS		APP'D:	P.M	DATE:	DATE:
DO NOT SCALE		SCALE:	2:1	SIZE:	A3
DIMENSIONS IN MILLIMETRES		THIRD ANGLE PROJECTION		CAD FILE	55011289000220

Amphenol Amphenol Australia Pty.Ltd.
22 Industry Blvd, Carrum Downs, VIC 3201

TITLE: **AC3FBV1-AU-PRE B-TYPE VERTICAL CUSTOMER DRAWING**

PART No: **SEE PN TABLE**

DRAWING NO. **55011289-000-2** SHEET **2/2**