

ASSEMBLY & DISASSEMBLY INSTRUCTION PI 1073 HPT-3-M - MALE POWER CONNECTOR ASSEMBLY

A. ASSEMBLY INSTRUCTION

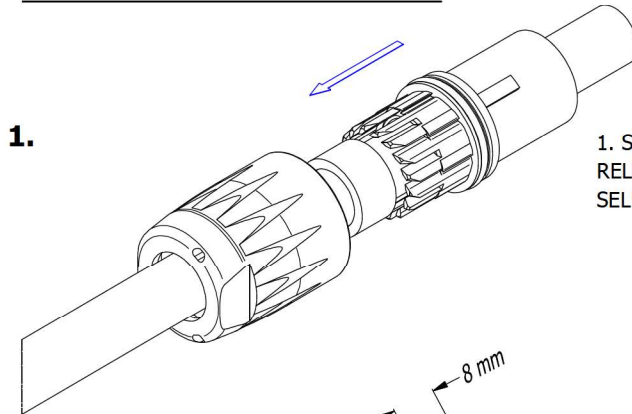

1. SLIDE THE BACKSHELL & GROMMET AND STRAIN RELIEF HOUSING ONTO THE CABLE.

SELECT GROMMET SIZE AS FOLLOWS:

- SMALL GROMMET : 6.0 - 9.0 mm CABLE OD.
- BIG GROMMET : 9.0 - 12.0 mm CABLE OD.

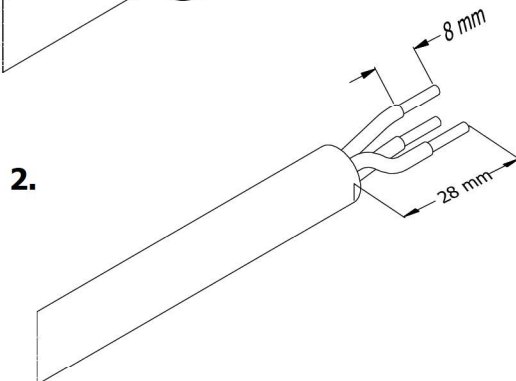

2. STRIP THE CABLE AS SPECIFIED DIMENSIONS.

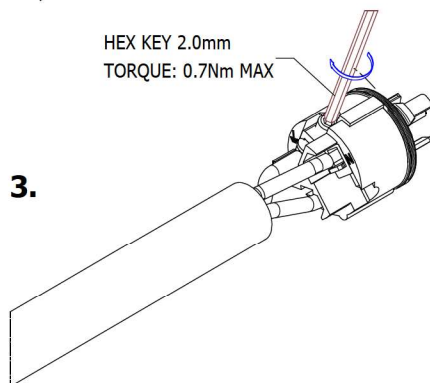

3. INSERT THE CONDUCTORS INTO THE REAR OF THE CONTACTS. TIGHTEN SCREWS TO 0.7Nm USING HEX ALLEN KEY 2.0MM

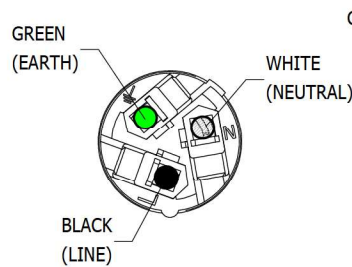

UL WIRING

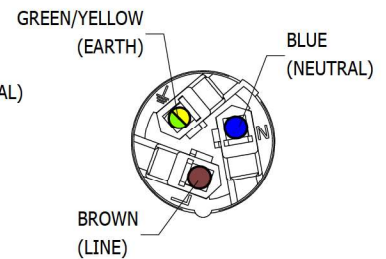

VDE WIRING

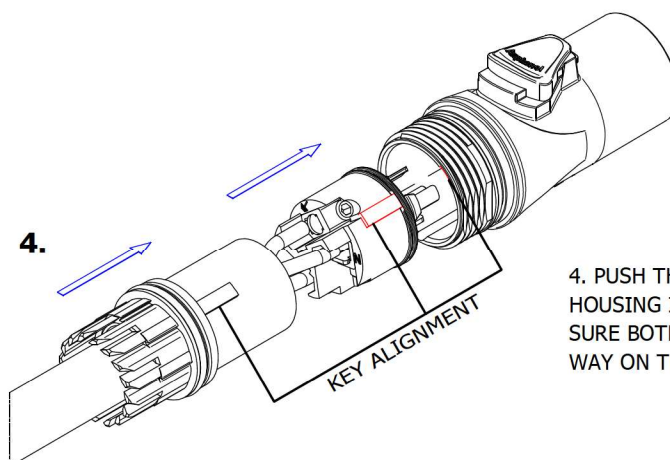

4. PUSH THE INSERT AND THEN THE STRAIN RELIEF HOUSING INTO THE CONNECTOR HOUSING, MAKING SURE BOTH SQUARE KEY ALIGN WITH THE SQUARE KEY WAY ON THE HOUSING.

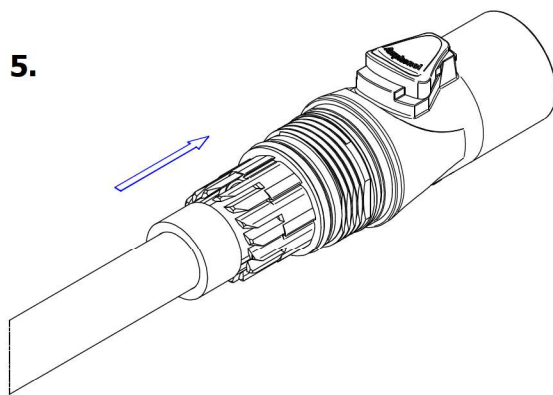

5.

5. PUSH THE GROMMET INTO THE STRAIN RELIEF HOUSING.

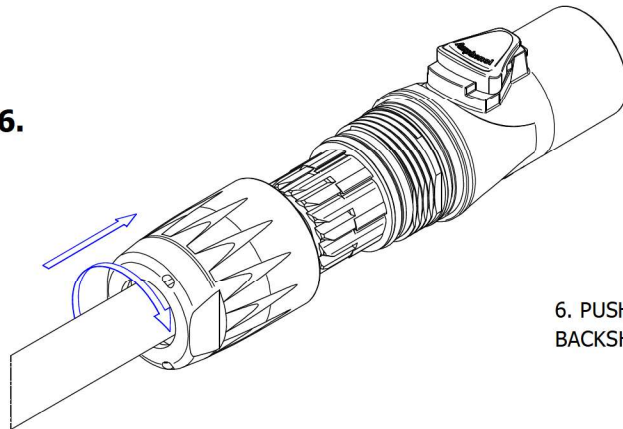

6.

6. PUSH AND TURN SIMULTANEOUSLY THE BACKSHELL ONTO THE CONNECTOR HOUSING

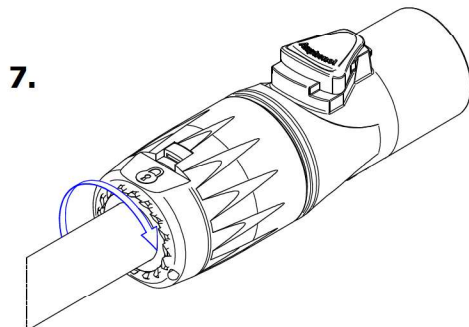

7.

7. TIGHTEN THE BACKSHELL TO 3.1 Nm MAX TO CLOSE THE CONNECTOR ASSEMBLY.

B. DISASSEMBLY INSTRUCTION

1. INSERT THE RELEASE TOOL "HPT-RT" ONTO THE BACKSHELL

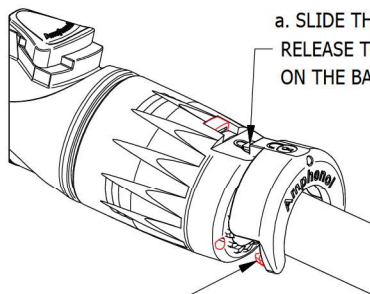

a. SLIDE THE BLADE OF THE RELEASE TOOL INTO THE SLOT ON THE BACK SHELL.

b. THEN PRESS TWO PINS ON THE RELEASE TOOL INTO TWO HOLES ON THE BACKSHELL.

2. TURN THE BACKSHELL COUNTER-CLOCKWISE TO REMOVE

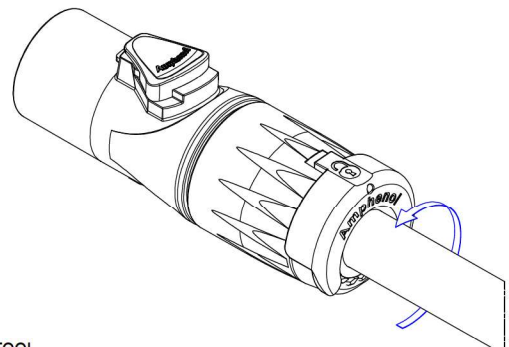

NOTE: ALTERNATIVELY A SMALL FLAT BLADED SCREWDRIVER CAN BE USED TO INSERT INTO THE SLOT THEN SIMULTANEOUSLY LIFT AND TURN THE BACKSHELL.