

LEGEND = KEY PRODUCT CHARACTERISTICS

REVISION HISTORY

REV	DESCRIPTION	DATE	BY	ECN
1	FIRST ISSUE	01/02/19	MH	----

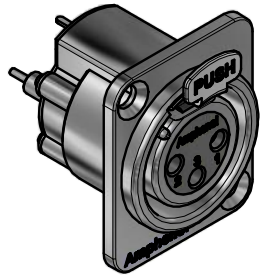

3D VIEW

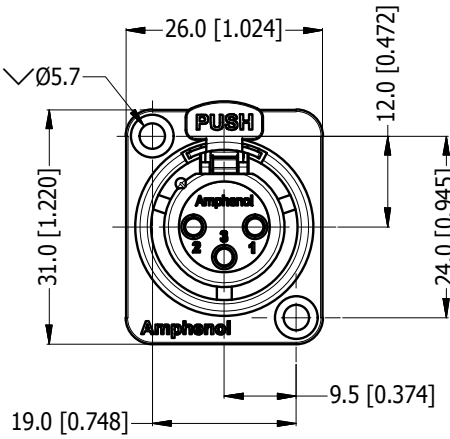

THROUGH HOLE

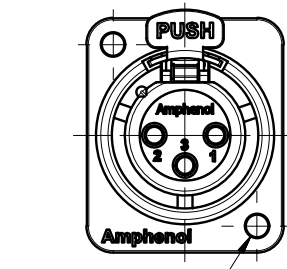
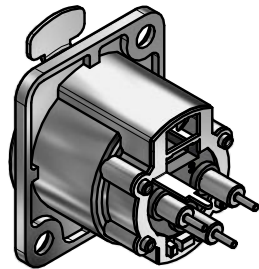
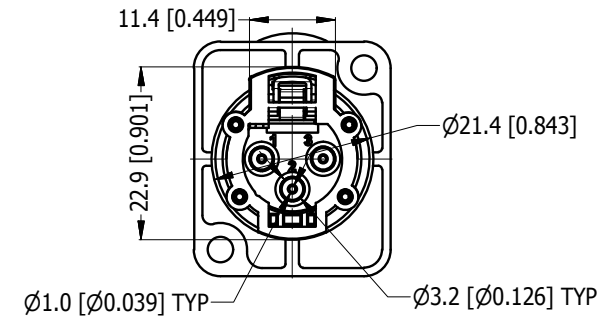
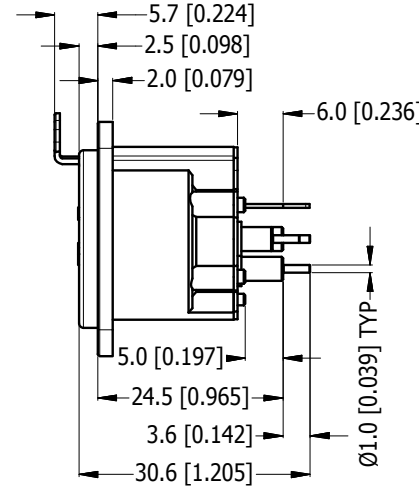

M3 THREAD OPTION

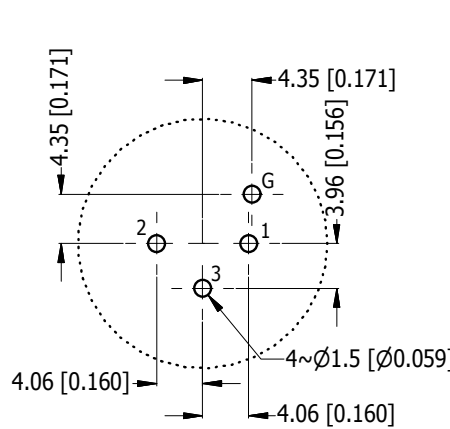

PCB LAYOUT

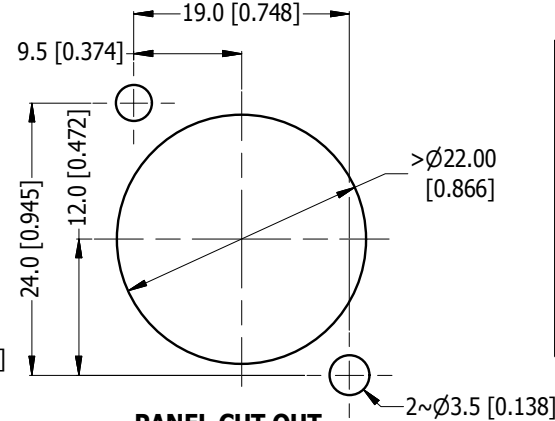

PANEL CUT OUT
(SCALE 2:1)

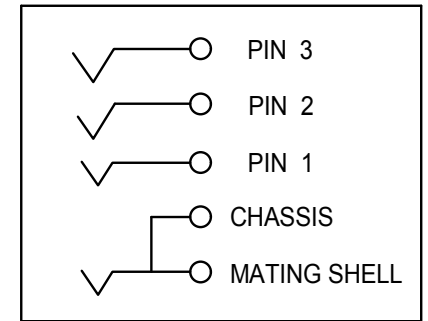

SCHEMATIC CHART

PART NUMBER	SHELL FINISH	PIN CONTACT FINIS
AX3FMDV	NICKEL PLATED	TIN PLATED
AX3FMDVB	MATT BLACK COATING	TIN PLATED
AX3FMDV-M3	M3 THREAD - NICKEL PLATED	TIN PLATED
AX3FMDVB-M3	M3 THREAD - MATT BLACK COATING	TIN PLATED
AX3FMDV-AU	NICKEL PLATED	GOLD PLATED
AX3FMDVB-AU	MATT BLACK COATING	GOLD PLATED
AX3FMDV-AU-M3	M3 THREAD - NICKEL PLATED	GOLD PLATED
AX3FMDVB-AU-M3	M3 THREAD - MATT BLACK COATING	GOLD PLATED

UNLESS OTHERWISE SPECIFIED TOLERANCE TO BE	
LINEAR	ANGULAR
X \pm 0.5	X' \pm 1
X.X \pm 0.2	X.X' \pm 30'
X.XX \pm 0.1	X.XX" \pm 15'

BREAK ALL SHARP EDGES AND REMOVE ALL BURRS

DO NOT SCALE

DIMENSIONS IN MILLIMETRES

THIS DOCUMENT IS THE PROPERTY OF AMPHENOL AUSTRALIA PTY. LTD.
NO PART THEREOF MAY BE REPRODUCED AND USED
WITHOUT THE PRIOR WRITTEN CONSENT OF THE OWNER

MATERIAL: **SEE COMPONENT**

FINISH: **SEE COMPONENT**



THIRD ANGLE PROJECTION

DRN: M.H DATE: 01/04/14

CKD: M.H DATE: 01/02/19

APP'D: P.M DATE: 01/02/19

SCALE: **1:1** SIZE: **A4**

Amphenol

Amphenol Australia Pty.Ltd,
22 Industry Boulevard, Carrum Downs, VIC 3201

TITLE:
**AX3FMDV
D-TYPE AX PCB PANEL MOUNT
CUSTOMER DWG**

PART No.
SEE TABLE

DRAWING No. **55011347-100-2** SHEET **2/2**

CAD FILE 55011347100111