

LEGEND

◆ = KEY PRODUCT CHARACTERISTICS

○ = CRITICAL INSPECTION DIMENSIONS

| REVISION HISTORY |  |    |       |          |      |
|------------------|--|----|-------|----------|------|
| REV              | DESCRIPTION                            | BY | APP'D | DATE     | ECN  |
| 1                | FIRST ISSUED                           | MH | PM    | 10-08-16 | ---- |
| 2                | CHANGE FROM MATT TO ZINC BLACK PLATING | MH | PM    | 10-08-16 | 9389 |

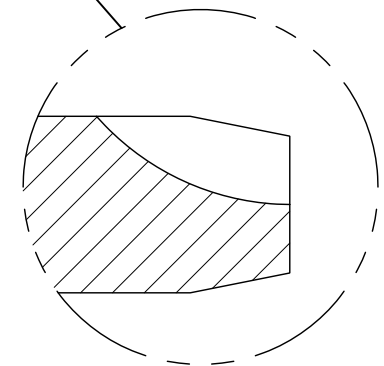
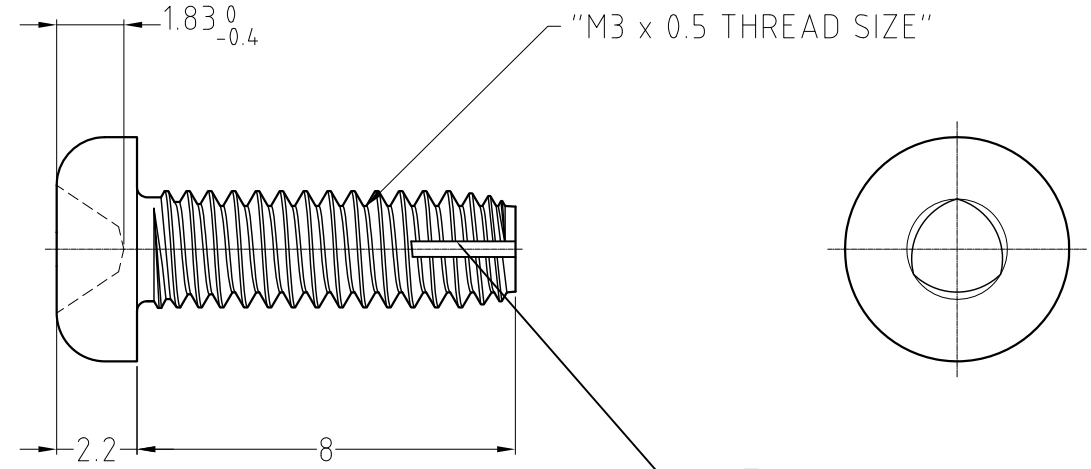
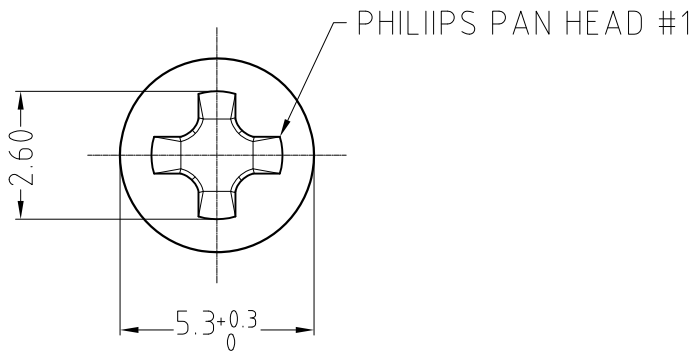

|              |                    |
|--------------|--------------------|
| 52500016-300 | NICKEL PLATE       |
| 52500016-400 | BLACK ZINC PLATING |
| PART NUMBER  | FINISH             |

NOTE:  
 1.MATERIAL: CARBON STEEL C1018A.  
 PARTS TO BE HEAT TREATED TO HARDEN  
 TO HARDNESS OF 55 HRC

|  |                                       |  |            |                |                       |  |                               |
|--|---------------------------------------|--|------------|----------------|-----------------------|--|-------------------------------|
| UNLESS OTHERWISE SPECIFIED TOLERANCE TO BE |                                       | THIS DOCUMENT IS THE PROPERTY OF AMPHENOL AUSTRALIA PTY. LTD.. NO PART THEREOF MAY BE REPRODUCED AND USED WITHOUT THE PRIOR WRITTEN CONSENT OF THE OWNER |            |                |                       | <b>Amphenol</b> Amphenol Australia Pty Ltd<br>22 Industry Blvd Carrum Downs VIC 3201 |                               |
| LINEAR                                     | ANGULAR                               | MATL: CARBON STEEL<br>SEE NOTE   | DRN: MH    | DATE: 10-08-16 | TITLE: SCREW M3 x 0.5 |  | PART No: SEE TABLE            |
| X ± 0.5<br>X,X ± 0.1<br>X,XX ± .N          | X° ± 1°<br>X°X' ± 30'<br>X°X'X" ± 15' |  | CKD: MH    | DATE: 05-12-16 |                       |  | DRAWING NO.<br>52500016-300-1 |
| BREAK ALL SHARP EDGES AND REMOVE ALL BURRS |                                       | FINISH: REFER TABLE  | APP'D: PM  | DATE: 05-12-16 |                       |  |                               |
| DIMENSIONS IN MILLIMETRES                  |                                       | THIRD ANGLE PROJECTION   | SCALE: 5:1 | SIZE: A4       |                       |  |                               |