

LEGEND  = KEY PRODUCT CHARACTERISTICS

REVISION HISTORY

REV	DESCRIPTION	DATE	BY	ECN
0	FIRST ISSUE	09/06/21	MH	----

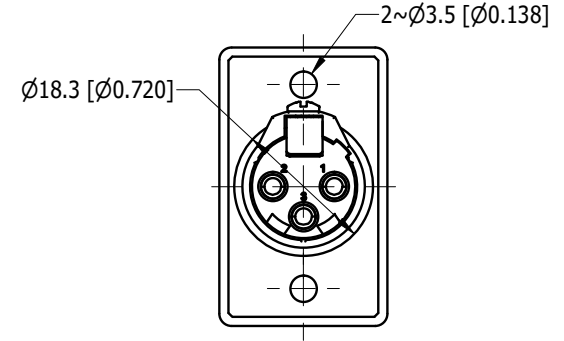
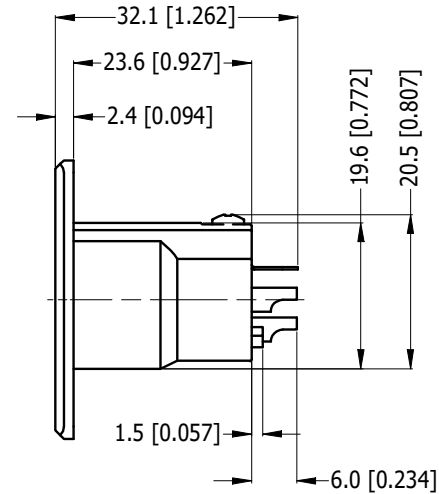
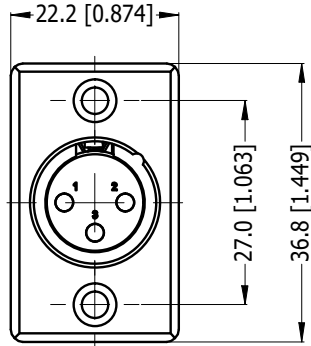
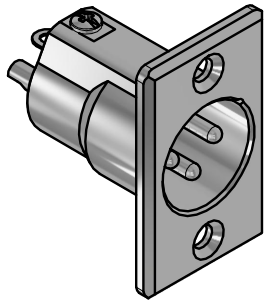

3D VIEWS

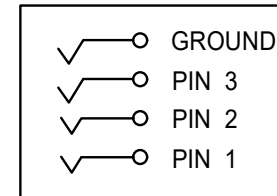
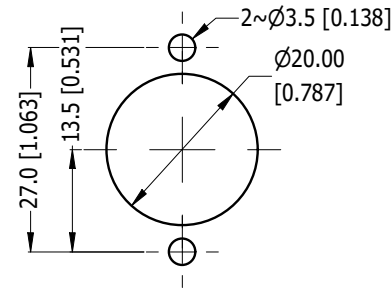
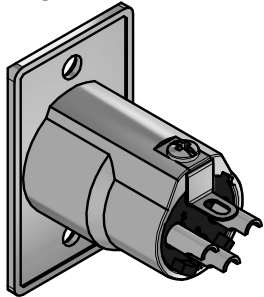

NOTES: ADD "BULK" TO THE PN FOR BULK PACKING, FOR EXAMPLE AC3MMPNZ BULK

RECOMMENDED PANEL CUT OUT

SCHEMATIC CHART

PART NUMBER	SHELL FINISH	CONTACT FINISH
AC3MMPNZ	NICKEL PLATED	SILVER PLATED
AC3MMPNZB	MATT BLACK COATING	SILVER PLATED
AC3MMPNZ-AU	NICKEL PLATED	GOLD PLATED
AC3MMPNZB-AU	MATT BLACK COATING	GOLD PLATED

UNLESS OTHERWISE SPECIFIED TOLERANCE TO BE		THIS DOCUMENT IS THE PROPERTY OF AMPHENOL AUSTRALIA PTY. LTD. NO PART THEREOF MAY BE REPRODUCED AND USED WITHOUT THE PRIOR WRITTEN CONSENT OF THE OWNER			
LINEAR		ANGULAR		MATERIAL: SEE COMPONENT	DRN: M.H
X ± 0.5	X' ± 1			CD: M.H	DATE: 09/06/21
X.X ± 0.2	X.X' ± 30'			APP'D: P.M	DATE: 09/06/21
X.XX ± 0.1	X.XX" ± 15'				
BREAK ALL SHARP EDGES AND REMOVE ALL BURRS		DO NOT SCALE		FINISH: SEE TABLE	
DIMENSIONS IN MILLIMETRES		THIRD ANGLE PROJECTION		SCALE: 1:1	SIZE: A4

Amphenol		Amphenol Australia Pty.Ltd, 22 Industry Boulevard, Carrum Downs, VIC 3201	
TITLE: AC3MMPNZ PANEL MOUNT CUSTOMER DWG		PART No. SEE TABLE	
CAD FILE: 55011453000110		DRAWING No. 55011453-003-1	SHEET 2/2