

LEGEND  = KEY PRODUCT CHARACTERISTICS

REVISION HISTORY

REV	DESCRIPTION	DATE	BY	ECN
0	FIRST ISSUE	09/06/21	MH	----

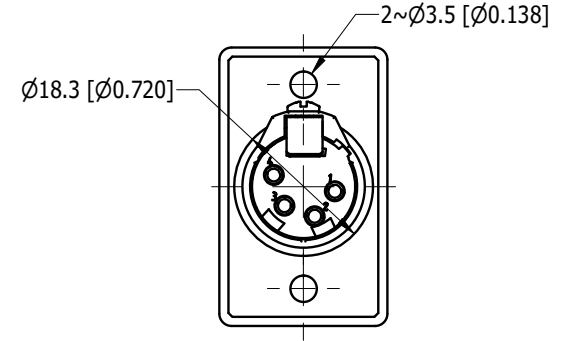
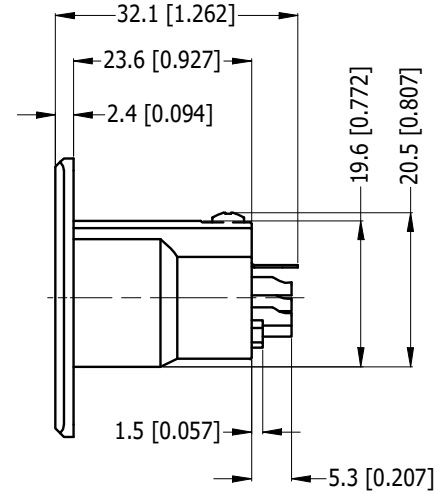
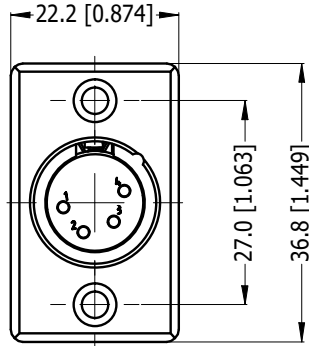
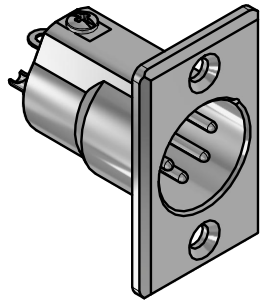

3D VIEWS

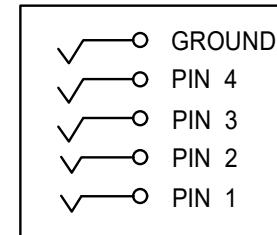
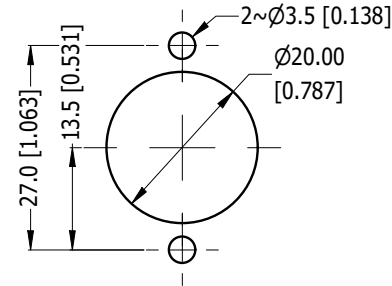
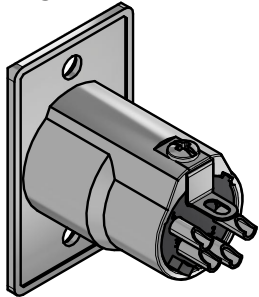

NOTES: ADD "BULK" TO THE PN FOR BULK PACKING, FOR EXAMPLE AC4MPNZ BULK

RECOMMENDED PANEL CUT OUT

SCHEMATIC CHART

PART NUMBER	SHELL FINISH	CONTACT FINISH
AC4MPNZ	NICKEL PLATED	SILVER PLATED
AC4MPNZB	MATT BLACK COATING	SILVER PLATED
AC4MPNZ-AU	NICKEL PLATED	GOLD PLATED
AC4MPNZB-AU	MATT BLACK COATING	GOLD PLATED

UNLESS OTHERWISE SPECIFIED TOLERANCE TO BE		THIS DOCUMENT IS THE PROPERTY OF AMPHENOL AUSTRALIA PTY. LTD. NO PART THEREOF MAY BE REPRODUCED AND USED WITHOUT THE PRIOR WRITTEN CONSENT OF THE OWNER			
LINEAR		ANGULAR		MATERIAL: <b>SEE COMPONENT</b>	DRN: M.H
X ± 0.5	X' ± 1				DATE: 09/06/21
X.X ± 0.2	X.X' ± 30'			FINISH: <b>SEE TABLE</b>	CKD: M.H
X.XX ± 0.1	X.XX" ± 15'				DATE: 09/06/21
BREAK ALL SHARP EDGES AND REMOVE ALL BURRS		DO NOT SCALE		APP'D: P.M	DATE: 09/06/21
DIMENSIONS IN MILLIMETRES		THIRD ANGLE PROJECTION		SCALE: <b>1:1</b>	SIZE: <b>A4</b>

**Amphenol** Amphenol Australia Pty.Ltd, 22 Industry Boulevard, Carrum Downs, VIC 3201

TITLE: **AC4MPNZ PANEL MOUNT CUSTOMER DWG**

PART No. **SEE TABLE**

DRAWING No. **55011453-004-1** SHEET **2/2**

CAD FILE: 55011453004110