

ISO VIEW
SCALE 1:1

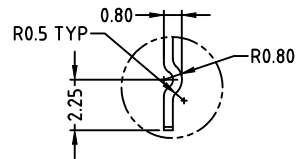

DETAIL A
SCALE 4:1

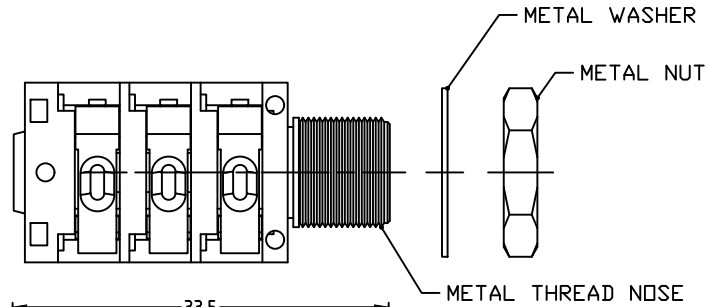
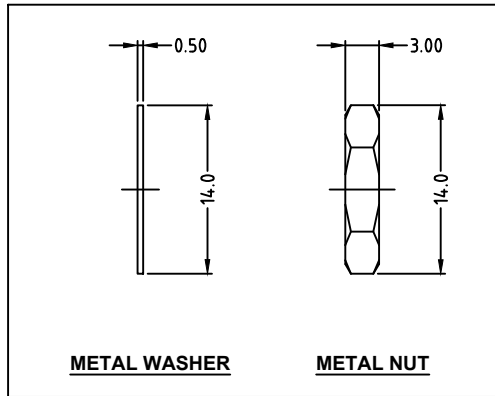
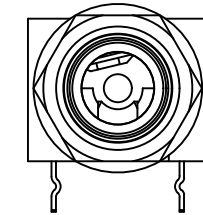
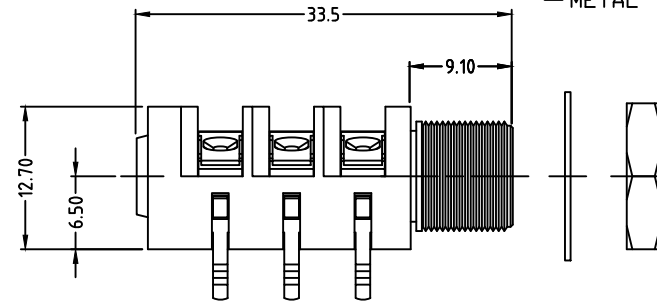
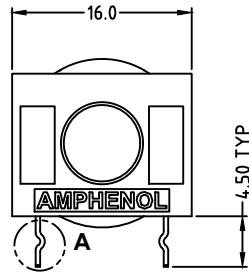

METAL WASHER

METAL NUT

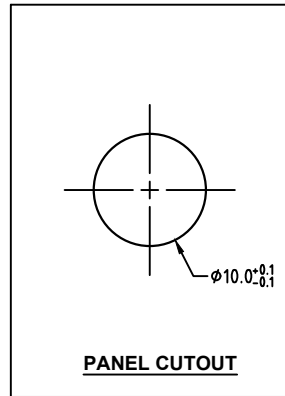

PANEL CUTOUT

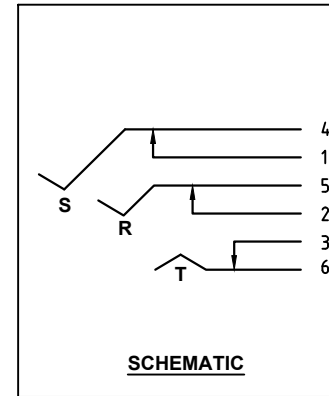

SCHEMATIC

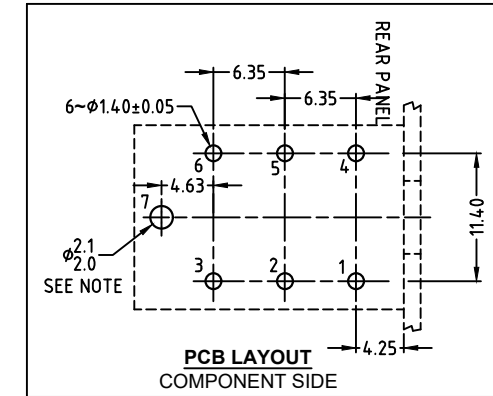

PCB LAYOUT
COMPONENT SIDE

NOTE: OPTIONAL MOUNTING HOLE FOR SELF-TAPPING M2 SCREW

2	CORRECT METAL NUT OD FROM 15mm TO 14mm	MH	07-02-23	9714
1	REDUCE METAL WASHER OD FROM 15mm TO 14mm	MH	20-04-16	9342
0	FIRST ISSUE	M.N.H	11-03-10	----
REV.	CHANGE DETAILS	BY	DATE	CHG/No

CATALOGUE P/N	NUT OPTION
ACJS-LHDRM	NO NUT & WASHER
ACJS-MHDRM	METAL NUT & WASHER INCLUDED

UNLESS OTHERWISE SPECIFIED TOLERANCE TO BE		THIS DOCUMENT IS THE PROPERTY OF AMPHENOL AUSTRALIA PTY. LTD.. NO PART THEREOF MAY BE REPRODUCED AND USED WITHOUT THE PRIOR WRITTEN CONSENT OF THE OWNER			
LINEAR	ANGULAR	CAD FILE: 55010661000112	DRN: M.H	DATE: 11-03-10	TITLE:
X ± 0.5 X.X ± 0.2 X.XX ± 0.1	X° ± 1° X°X' ± 30' X°X'X" ± 15'	MATL: REFER TO COMPONENTS	CKD: M.N.H	DATE: 07-02-23	1/4" PHONE STEREO JACK CUSTOMER DRAWING
BREAK ALL SHARP EDGES AND REMOVE ALL BURRS		FINISH: REFER TO COMPONENTS	APP'D: P.M	DATE: 07-02-23	
DO NOT SCALE		DIMENSIONS IN MILLIMETRES		SCALE: 2:1 UOS	PART No: REFER TO TABLE

Amphenol
Amphenol Australia Pty Ltd 22 Industry Blvd, Carrum Downs, Vic.3201
DRAWING NO. 55010661-000-2 SHEET 2 OF 2