

LEGEND = KEY PRODUCT CHARACTERISTICS

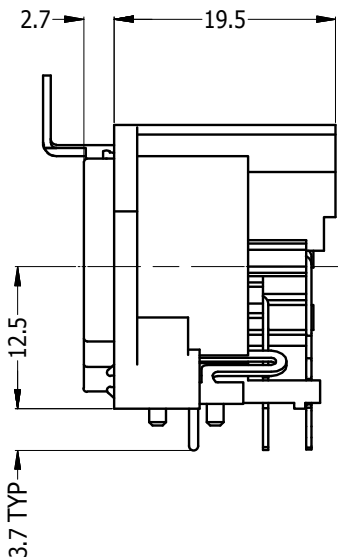

REV	DESCRIPTION	DATE	BY	ECN
0	FIRST ISSUE	20-08-08	MH	----
1	ADD -B TO PN	26-08-15	MH	----
2	CHANGE MATERIAL FROM UL94HB TO UL94V-0	01-04-20	MH	9593

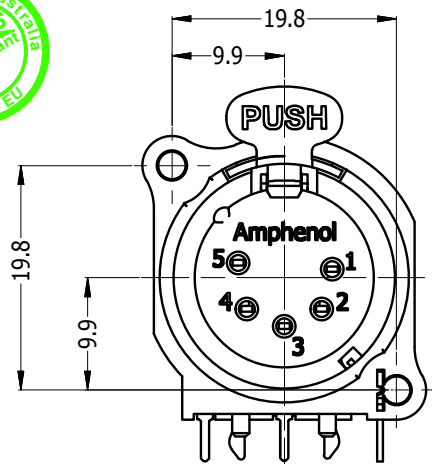
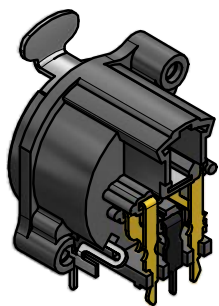
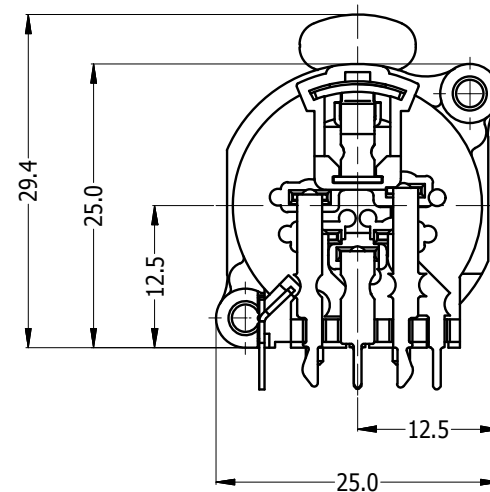

3D VIEW (1:1)

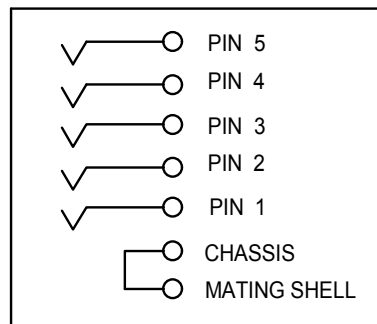

SCHMATIC CHART

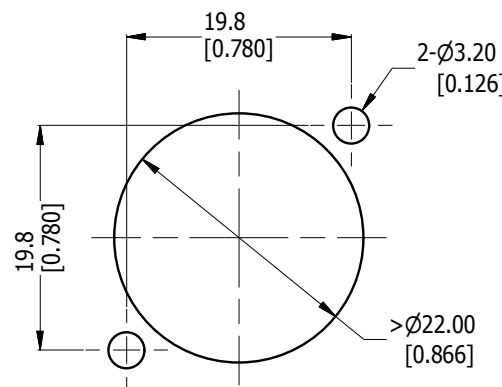

PANEL CUT OUT
REAR VIEW

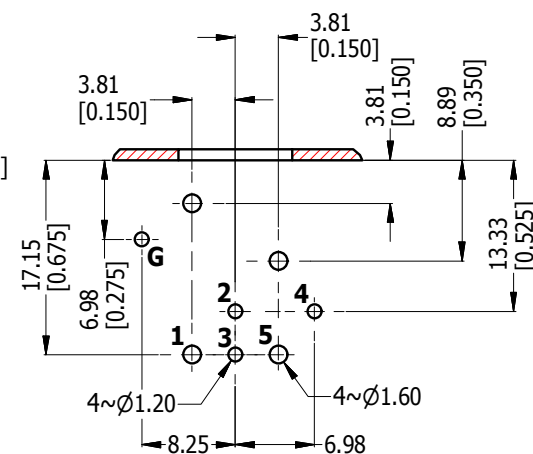

PCB LAYOUT
COMPONENT SIDE
TOLERANCE: ± 0.05mm [.002"]

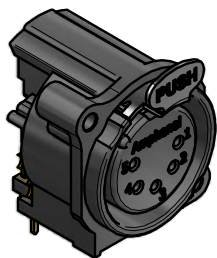

NOTE:
THE PUSH LEVER **52080004-331** SHALL NOT BE INSTALLED AND **MUST BE PACK IN BAG** OF 100 PER BOX.

UNLESS OTHERWISE SPECIFIED TOLERANCE TO BE	
LINEAR	ANGULAR
X ± 0.5	X' ± 1
X.X ± 0.2	X.X' ± 30'
X.XX ± 0.1	X.XX" ± 15'

BREAK ALL SHARP EDGES AND REMOVE ALL BURRS

DO NOT SCALE

DIMENSIONS IN MILLIMETRES

THIS DOCUMENT IS THE PROPERTY OF AMPHENOL AUSTRALIA PTY. LTD.
NO PART THEREOF MAY BE REPRODUCED AND USED
WITHOUT THE PRIOR WRITTEN CONSENT OF THE OWNER

MATERIAL: **SEE COMPONENT**

FINISH: **SEE COMPONENT**

THIRD ANGLE PROJECTION

DRN: M.H	DATE: 20-08-18
CKD: M.H	DATE: 20-08-18
APP'D: P.M	DATE: 20-08-18
SCALE: 3:2	SIZE: A4

Amphenol Amphenol Australia Pty.Ltd,
22 Industry Blvd, Carrum Downs, VIC 3201

TITLE:
**AC5FAH-AU-B
HORIZONTAL FEMALE
CUSTOMER DRAWING**

PART No.
AC5FAH-AU-B

DRAWING No.
55010445-000-2

SHEET
2/2