

ASSEMBLY INSTRUCTION PI 1086 HPT-3-FJ - FEMALE POWER CONNECTOR ASSEMBLY

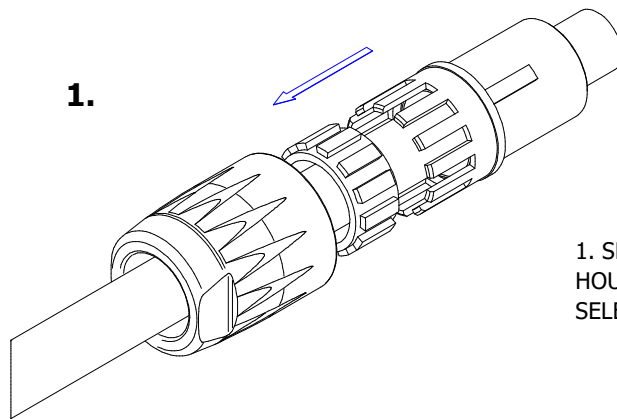

1. SLIDE THE BACKSHELL & GROMMET AND STRAIN RELIEF HOUSING ONTO THE CABLE.

SELECT GROMMET SIZE AS FOLLOWS:

- SMALL GROMMET : 7.5 - 10.0 mm CABLE OD.
- MEDIUM GROMMET : 9.5 - 13.0 mm CABLE OD.
- BIG GROMMET : 12.7 - 16.0 mm CABLE OD

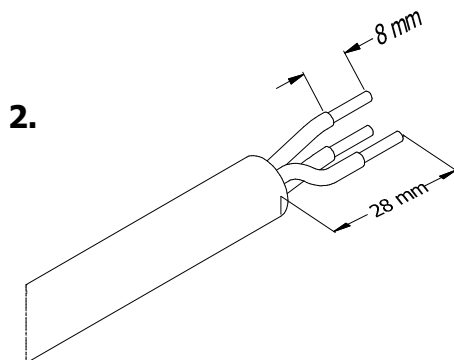

2. STRIP THE CABLE AS SPECIFIED DIMENSIONS.

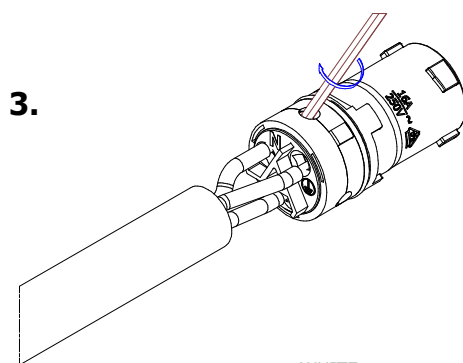

3. INSERT THE CONDUCTORS INTO THE REAR OF THE CONTACTS. TIGHTEN SCREW TO 0.7Nm USING HEX ALLEN KEY 2.0MM

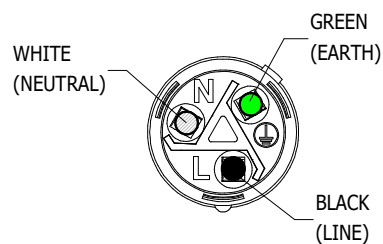

UL WIRING

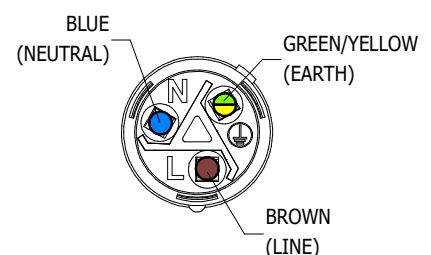

VDE WIRING

4.

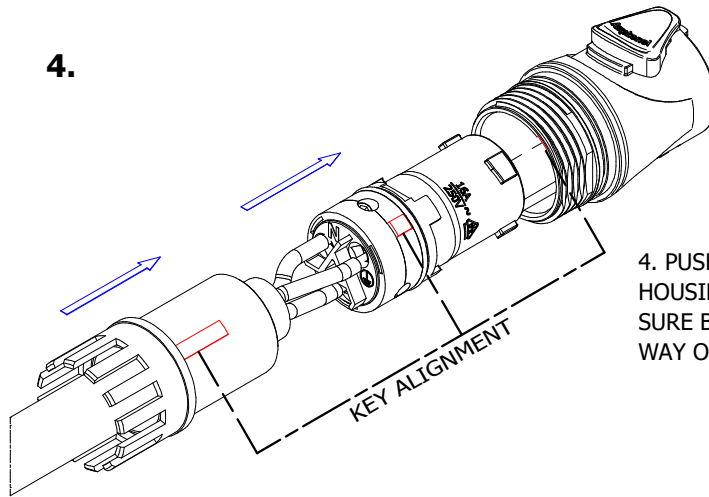

4. PUSH THE INSERT AND THEN THE STRAIN RELIEF HOUSING INTO THE CONNECTOR HOUSING, MAKING SURE BOTH SQUARE KEY ALIGN WITH THE SQUARE KEY WAY ON THE HOUSING.

5.

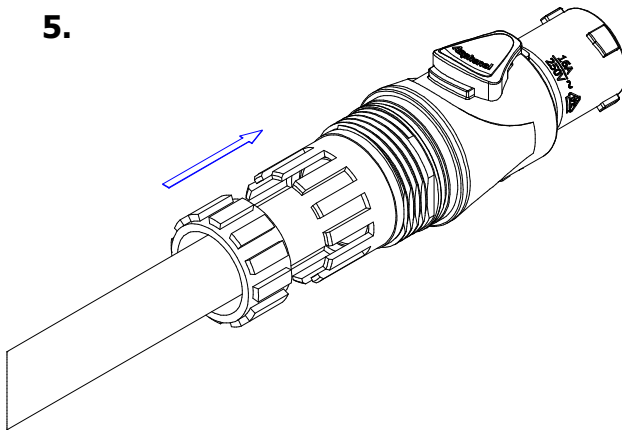

5. PUSH THE GROMMET INTO THE STRAIN RELIEF HOUSING.

6.

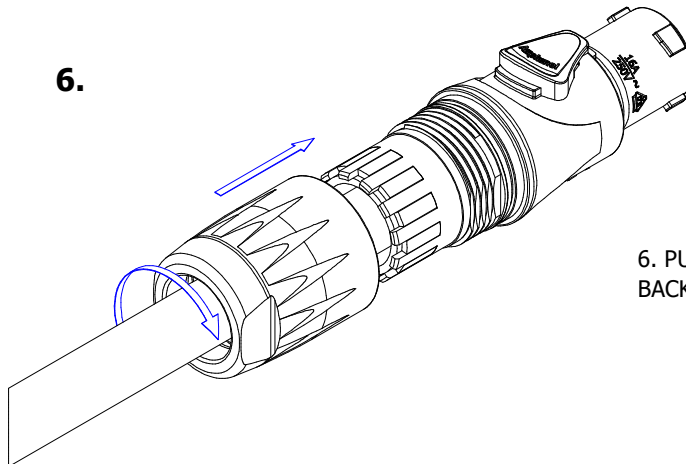

6. PUSH AND TURN SIMULTANEOUSLY THE BACKSHELL ONTO THE CONNECTOR HOUSING

7.

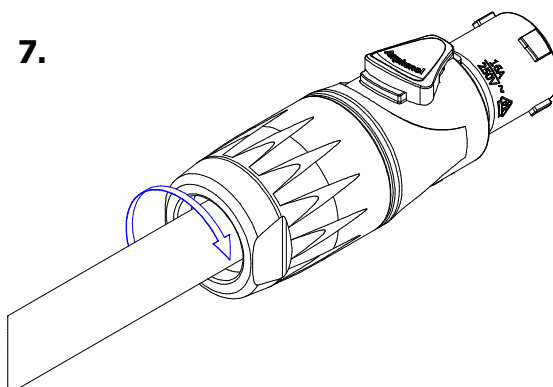

7. TIGHTEN THE BACKSHELL TO 3.7 Nm MAX TO CLOSE THE CONNECTOR ASSEMBLY.