

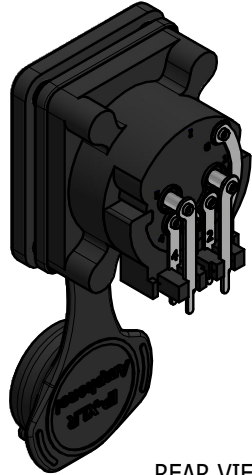

CAPPED VIEW

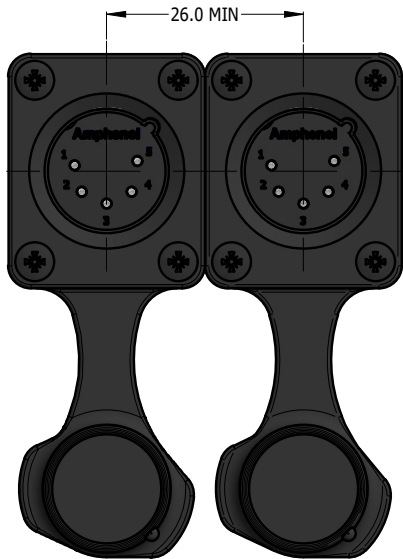

REAR VIEW

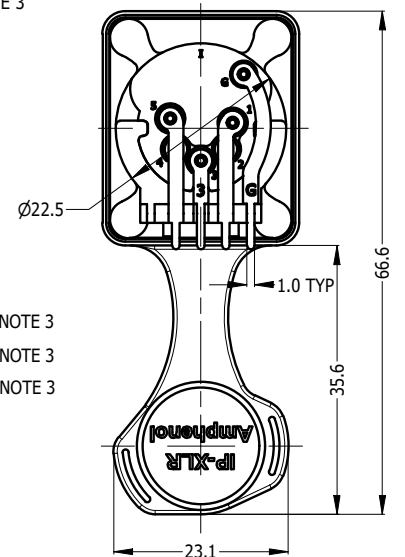
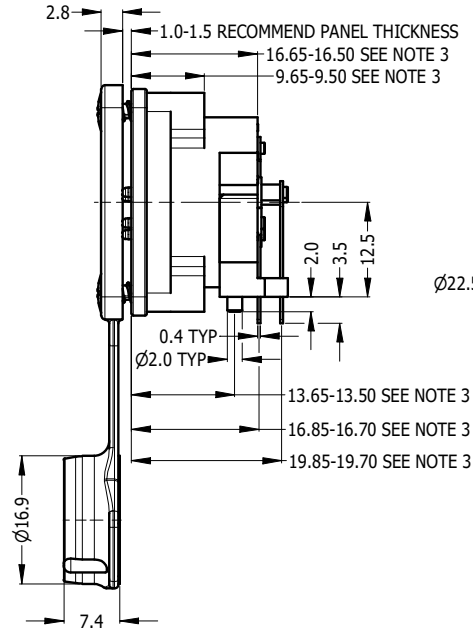
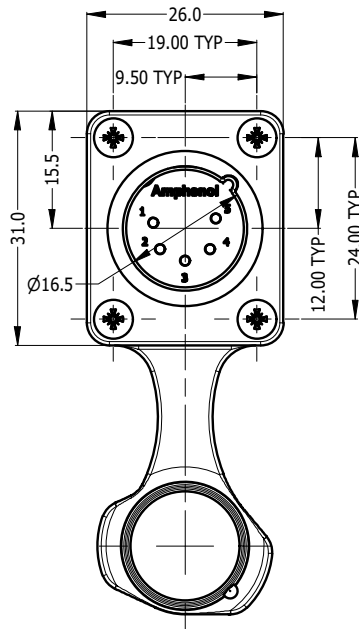

RECOMMEND MINIMUM MOUNTING PITCH

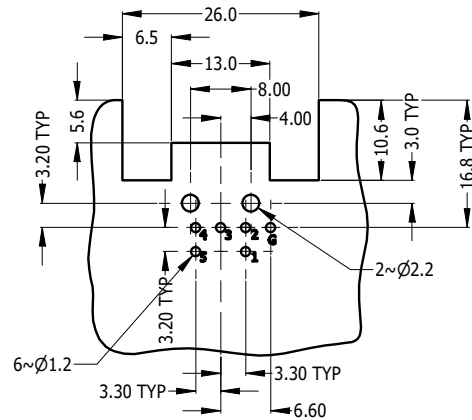
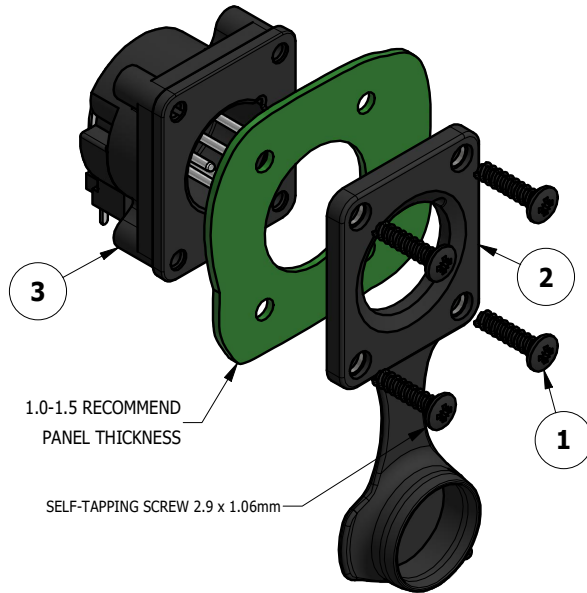

RECOMMEND PCB LAYOUT
CONNECTOR SIDE

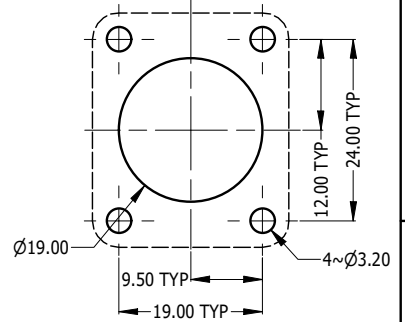

RECOMMEND PANEL CUT OUT

REVISION HISTORY				
REV	DESCRIPTION	DATE	BY	ECN
1	FIRST ISSUE	11-11-23	MH	----

NOTE:
 1. MATING CONNECTOR SHELL TO HAVE MIN 1.6 SURFACE FINISH TO ACHIEVE IP RATING OF THIS CONNECTOR.
 2. BLACK MOUNTING SCREW 52500011-430 x 4 PCS TO BE SUPPLIED WITH THE CONNECTOR, MAX TORQUE 0.5Nm.
 3. DUE TO 0.4mm THICK RUBBER SEAL, THE DIM WILL VARY DEPENDING ON THE SCREWS TIGHTENING IN ASSEMBLY.

ITEM	PART NUMBER	DESCRIPTION	QTY
3	55011501-005/905	AXS5MPH WITHOUT RUBBER FLANGE - TIN/GOLD PLATED CONTACT	1
2	52730035-000	AXS FRONT FLANGE D TYPE RUBBER SEAL IPS4 WITH CAP	1
1	52500011-430	SELF TAPPING SCREW 2.9 x 1.06mm BLACK	4

UNLESS OTHERWISE SPECIFIED TOLERANCE TO BE	
LINEAR	ANGULAR
X ± 0.5	X' ± 1
X.X ± 0.2	X.X' ± 30'
X.XX ± 0.1	X.XX" ± 15"

THIS DOCUMENT IS THE PROPERTY OF AMPHENOL AUSTRALIA PTY. LTD.
 NO PART THEREOF MAY BE REPRODUCED AND USED
 WITHOUT THE PRIOR WRITTEN CONSENT OF THE OWNER

BREAK ALL SHARP EDGES AND REMOVE ALL BURRS
 DO NOT SCALE
 DIMENSIONS IN MILLIMETRES

MATERIAL: SEE COMPONENT	DRN: M.H	DATE: 11-11-23
FINISH: SEE COMPONENT	CKD: M.H	DATE: 11-11-23
	APP'D: P.M	DATE: 11-11-23
	SCALE: 1:1	SIZE: A4

Amphenol Amphenol Australia Pty.Ltd,
 22 Industry Blvd, Carrum Downs, VIC 3201

TITLE: AXS5MPH AXS PANEL MOUNT SERIES CUSTOMER DRAWING	PART No. SEE TABLE
CAD FILE: 55011501805111	DRAWING No. 55011501-805-2
	SHEET 2/2