

LEGEND  = KEY PRODUCT CHARACTERISTICS

REVISION HISTORY				
REV	DESCRIPTION	BY	DATE	ECN
0	FIRST ISSUE	H.H	14-02-11	8990
1	UPDATE DRAWING TO CURRENT LOGO LOCATION	MH	10-10-22	9707

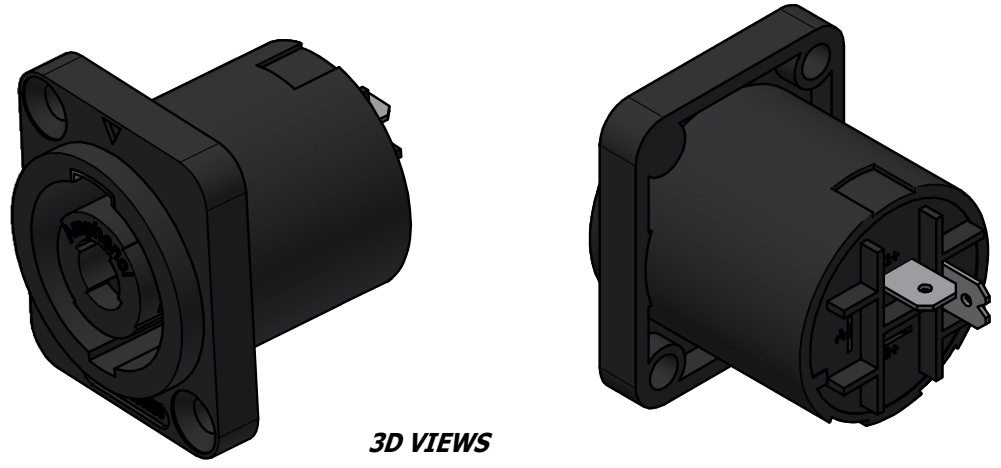
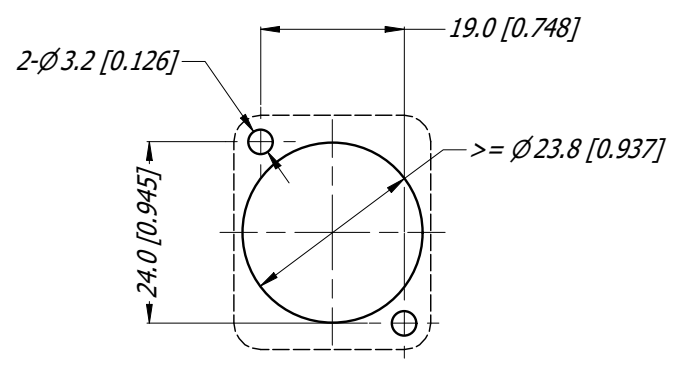
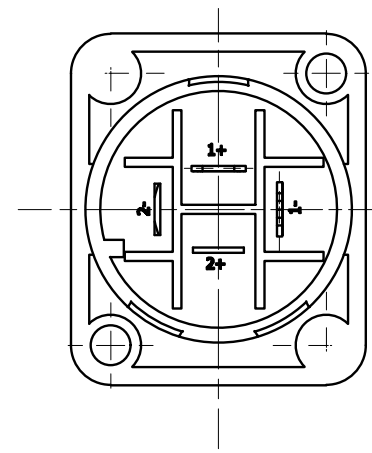
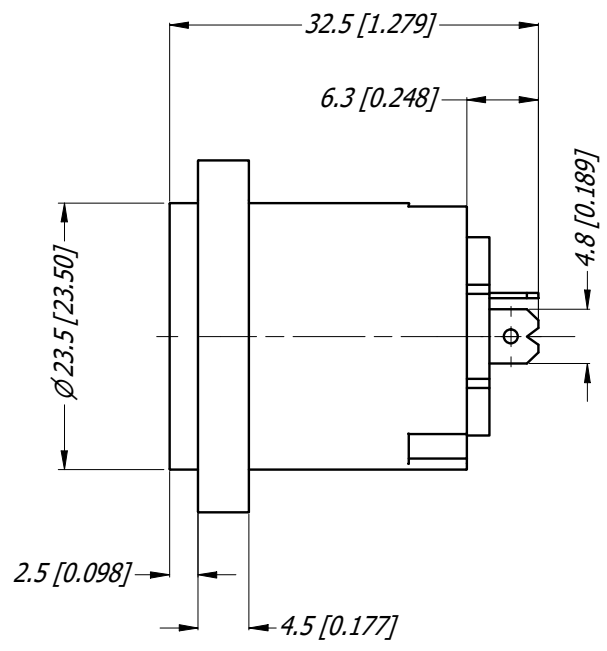
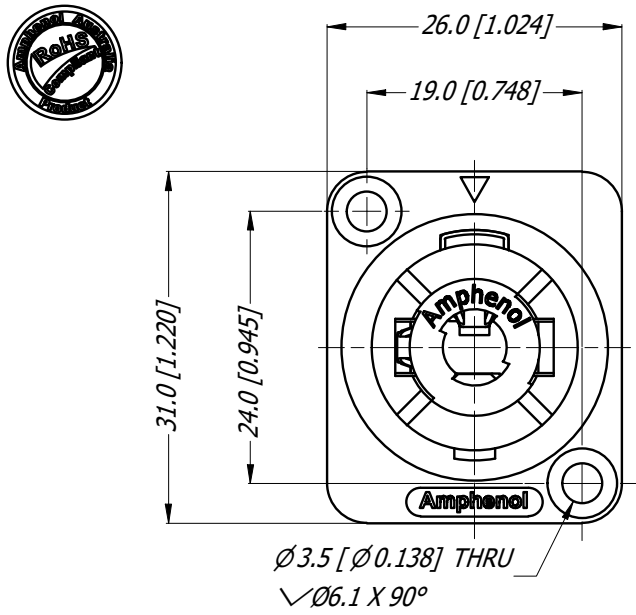

3D VIEWS

PANEL CUTOUT (1:1)

UNLESS OTHERWISE SPECIFIED TOLERANCE TO BE		THIS DOCUMENT IS THE PROPERTY OF AMPHENOL AUSTRALIA PTY. LTD. NO PART THEREOF MAY BE REPRODUCED AND USED WITHOUT THE PRIOR WRITTEN CONSENT OF THE OWNER			Amphenol Amphenol Australia Pty. Ltd. 22 Industry Blvd, Carrum Downs, VIC 3201		
LINEAR	ANGULAR	MATERIAL:	DRN:	DATE:	TITLE:	PART No.	
X ± 0.5	X° ± 1	REFER TO COMPONENTS	HH	10/02/11	SP SERIES CONNECTOR LOUDSPEAKER 2 POLE, SOLDER	SP-2-MD	
X.X ± 0.1	X.X° ± 30°	BREAK ALL SHARP EDGES AND REMOVE ALL BURRS	CKD:	DATE:			DRAWING No.
X.XX ± 0.05	X.XX° ± 15°	DO NOT SCALE	PM	14/02/11		55010735-000-2	2/2
DIMENSIONS IN MILLIMETRES		FINISH:	APP'D:	SCALE:	CAD FILE:		
				3:2	55010735000210		

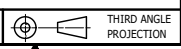

SCALE: **3:2** SIZE: **A4**