

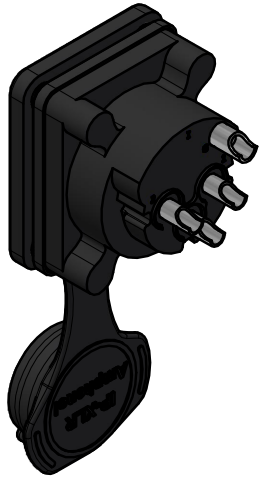

CAPPED VIEW

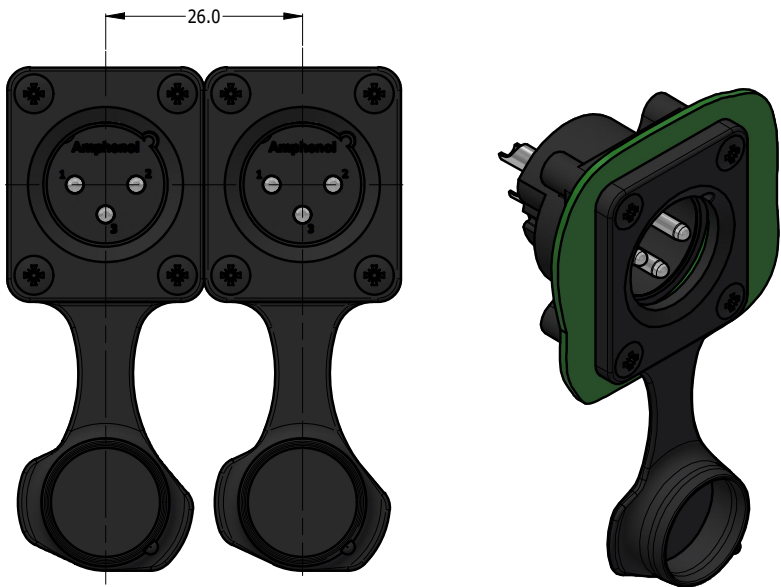

REAR VIEW

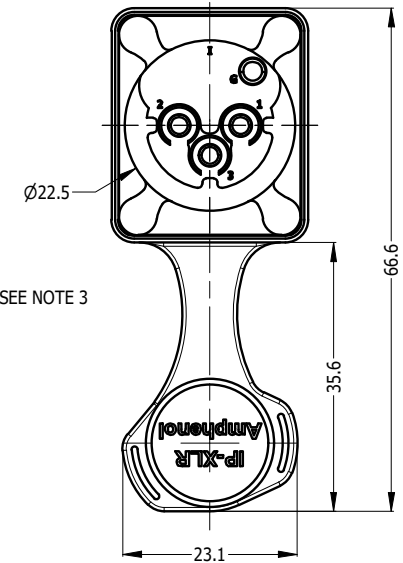
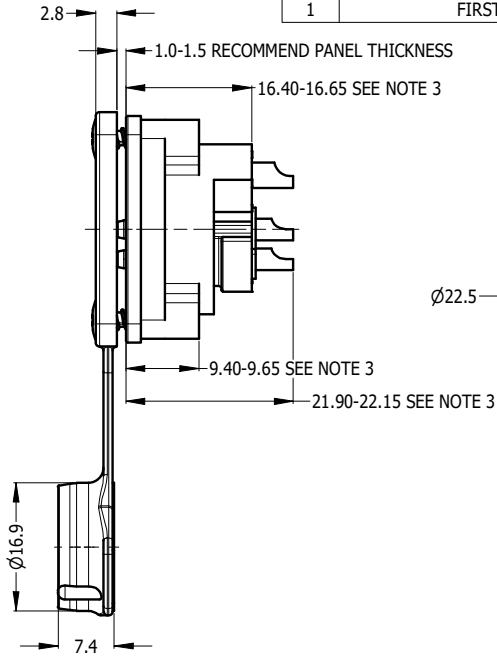
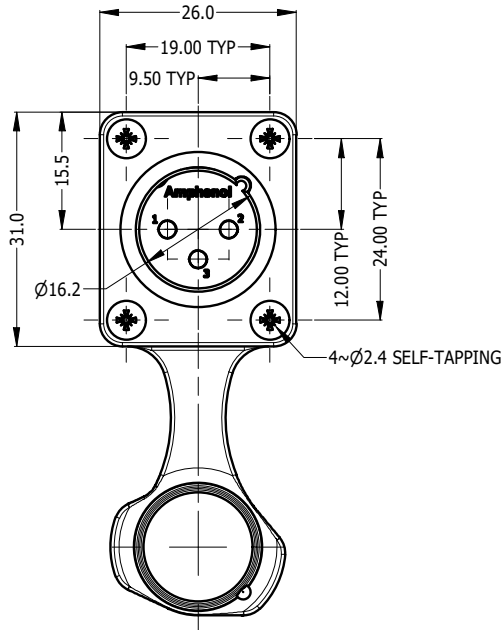

RECOMMEND MINIMUM MOUNTING PITCH

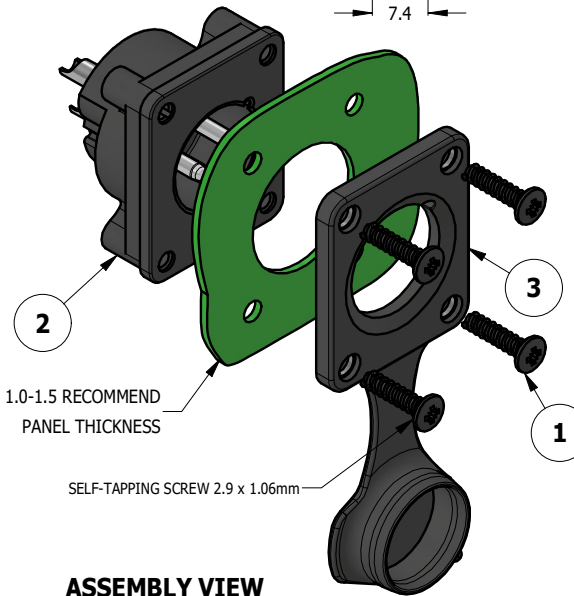

ASSEMBLY VIEW

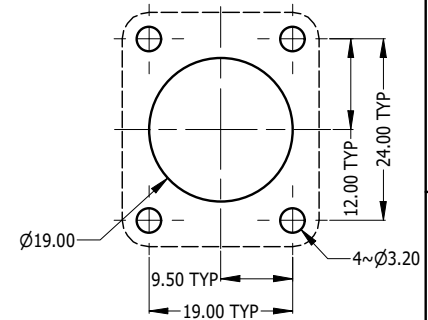

RECOMMEND PANEL CUT OUT

REVISION HISTORY				
REV	DESCRIPTION	DATE	BY	ECN
1	FIRST ISSUE	11-11-23	MH	----

PART NUMBER	CONTACT FINISH
AXS3MP	TIN PLATED
AXS3MP-AU	GOLD PLATED

- NOTE:
 1. MATING CONNECTOR SHELL TO HAVE MIN 1.6 SURFACE FINISH TO ACHIEVE IP RATING OF THIS CONNECTOR.
 2. BLACK MOUNTING SCREW 52500011-430 x 4 PCS TO BE SUPPLIED WITH THE CONNECTOR, MAX TORQUE 0.5Nm.
 3. DUE TO 0.4mm THICK RUBBER SEAL, THE DIM WILL VARY DEPENDING ON THE SCREWS TIGHTENING IN ASSEMBLY.

ITEM	PART NUMBER	DESCRIPTION	QTY
3	52730035-800	AXS OVERMOLDED RUBBER FLANGE BLACK	1
2	55011499-003/903	AXS3MHV WITHOUT RUBBER FLANGE - TIN/GOLD PLATED CONTACT	1
1	52500011-430	SELF TAPPING SCREW 2.9 x 1.06mm BLACK	4

UNLESS OTHERWISE SPECIFIED TOLERANCE TO BE	
LINEAR	ANGULAR
X ± 0.5	X' ± 1
X.X ± 0.2	X.X' ± 30'
X.XX ± 0.1	X.XX" ± 15'

BREAK ALL SHARP EDGES AND REMOVE ALL BURRS

DO NOT SCALE

THIS DOCUMENT IS THE PROPERTY OF AMPHENOL AUSTRALIA PTY. LTD.
 NO PART THEREOF MAY BE REPRODUCED AND USED WITHOUT THE PRIOR WRITTEN CONSENT OF THE OWNER

MATERIAL: SEE COMPONENT	DRN: M.H	DATE: 11-11-23
FINISH: SEE COMPONENT	CKD: M.H	DATE: 11-11-23
	APP'D: P.M	DATE: 11-11-23

Amphenol Amphenol Australia Pty.Ltd,
 22 Industry Blvd, Carrum Downs, VIC 3201

TITLE: AXS3MP AXS PANEL MOUNT SERIES CUSTOMER DRAWING	PART No. SEE TABLE
SCALE: 1:1	DRAWING No. 55011499-803-2
SIZE: A4	SHEET 2/2

DIMENSIONS IN MILLIMETRES



THIRD ANGLE PROJECTION