

CAPPED VIEW

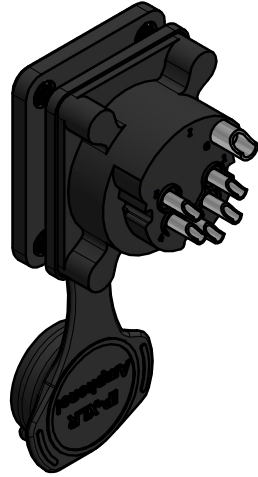

REAR VIEW

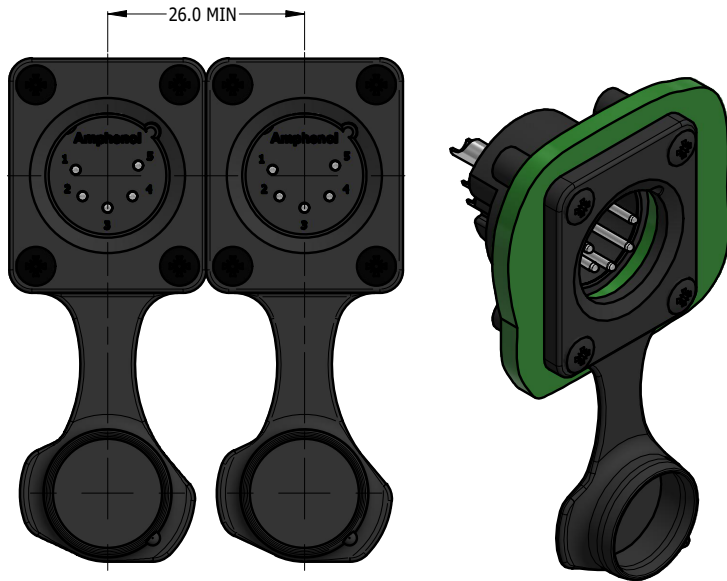
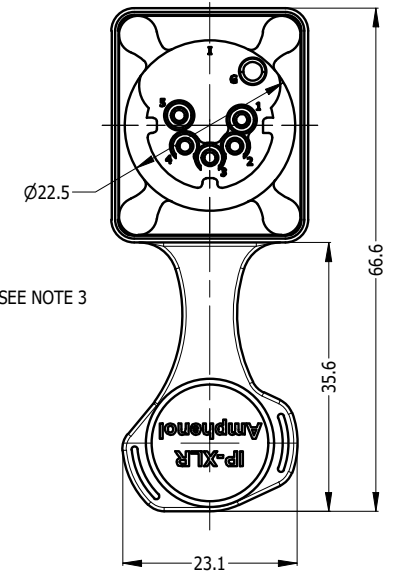
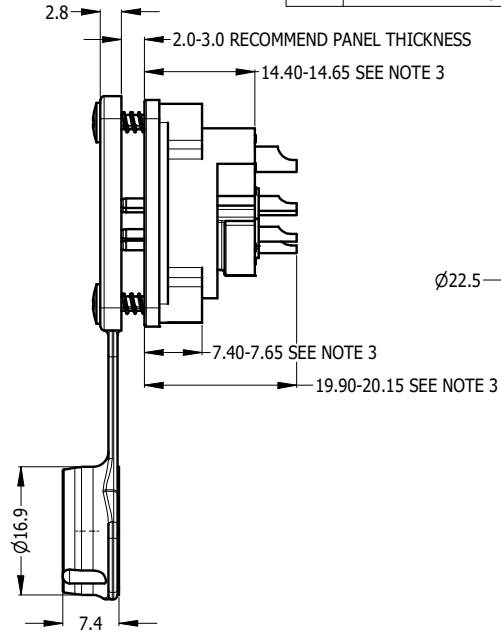
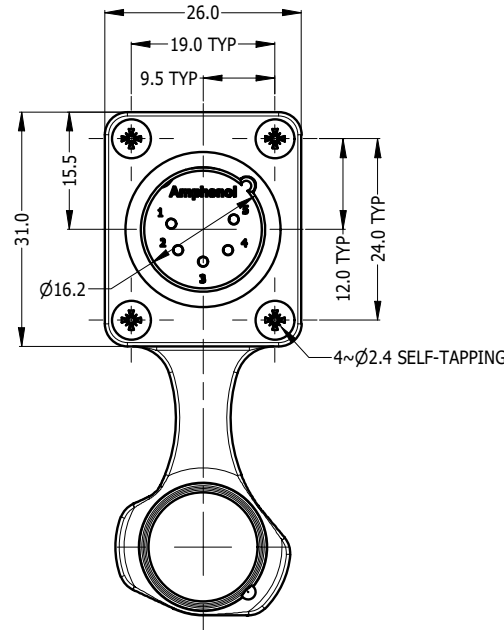

RECOMMEND MINIMUM MOUNTING PITCH

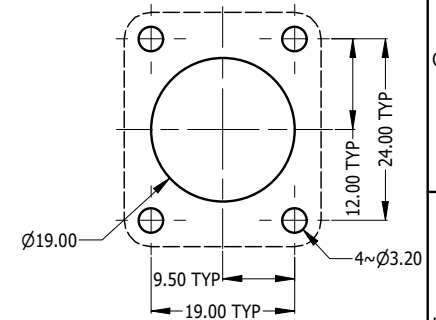
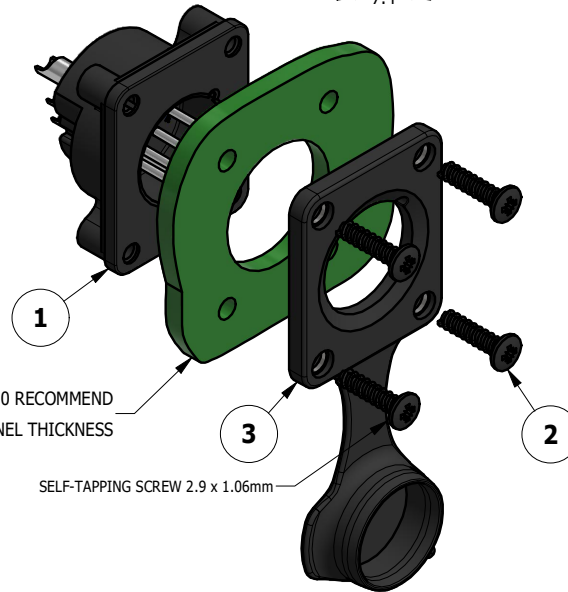

RECOMMEND PANEL CUT OUT

REVISION HISTORY				
REV	DESCRIPTION	DATE	BY	ECN
1	FIRST ISSUE	11-11-23	MH	----

- NOTE:  
 1. MATING CONNECTOR SHELL TO HAVE MIN 1.6 SURFACE FINISH TO ACHIEVE IP54 RATING OF THIS CONNECTOR.  
 2. BLACK MOUNTING SCREW 52500011-430 x 4 PCS TO BE SUPPLIED WITH THE CONNECTOR, MAX TORQUE 0.5Nm.  
 3. DUE TO 0.4mm THICK RUBBER SEAL, THE DIM WILL VARY DEPENDING ON THE SCREWS TIGHTENING IN ASSEMBLY.

ITEM	PART NUMBER	DESCRIPTION	QTY
3	52730035-000	AXS FRONT FLANGE D TYPE RUBBER SEAL IP54 WITH CAP	1
2	52500011-430	SCREW 2.9 x 1.06mm USED FOR PLASTIC MATERIAL	4
1	55011499-025/925	AXS5MP2 WITHOUT RUBBER FLANGE - TIN/GOLD PLATED CONTACT	1

UNLESS OTHERWISE SPECIFIED TOLERANCE TO BE	
LINEAR	ANGULAR
X ± 0.5	X' ± 1
X.X ± 0.2	X.X' ± 30'
X.XX ± 0.1	X.XX" ± 15"

BREAK ALL SHARP EDGES AND REMOVE ALL BURRS

DO NOT SCALE

THIS DOCUMENT IS THE PROPERTY OF AMPHENOL AUSTRALIA PTY. LTD.  
 NO PART THEREOF MAY BE REPRODUCED AND USED WITHOUT THE PRIOR WRITTEN CONSENT OF THE OWNER

MATERIAL: <b>SEE COMPONENT</b>	DRN: M.H	DATE: 11-11-23
FINISH: <b>SEE COMPONENT</b>	CKD: M.H	DATE: 11-11-23
	APP'D: P.M	DATE: 11-11-23

DIMENSIONS IN MILLIMETRES

**Amphenol** Amphenol Australia Pty.Ltd,  
 22 Industry Blvd, Carrum Downs, VIC 3201

TITLE: <b>AXS5MP2 AXS PANEL MOUNT SERIES CUSTOMER DRAWING</b>	PART No. <b>SEE TABLE</b>
SCALE: <b>1:1</b>	DRAWING No. <b>55011499-825-2</b>
SIZE: <b>A4</b>	SHEET <b>2/2</b>

CAD FILE: 55011499825110