

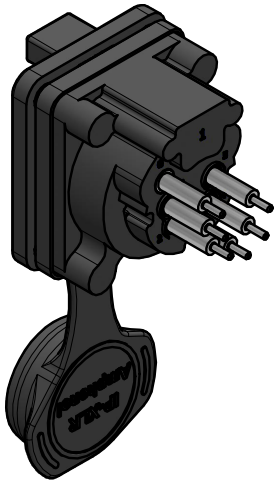

CAPPED VIEW

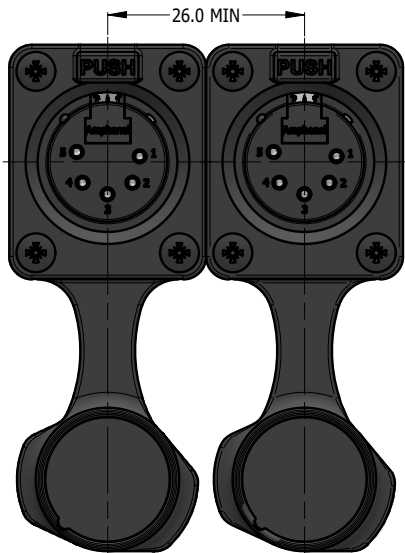

REAR VIEW

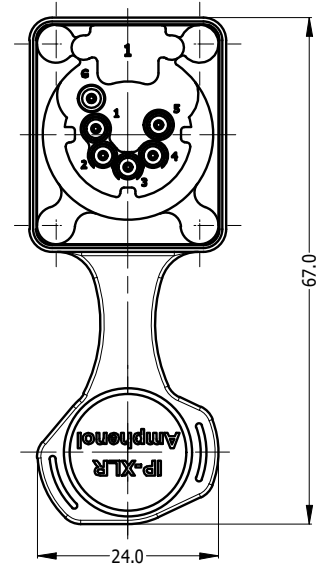
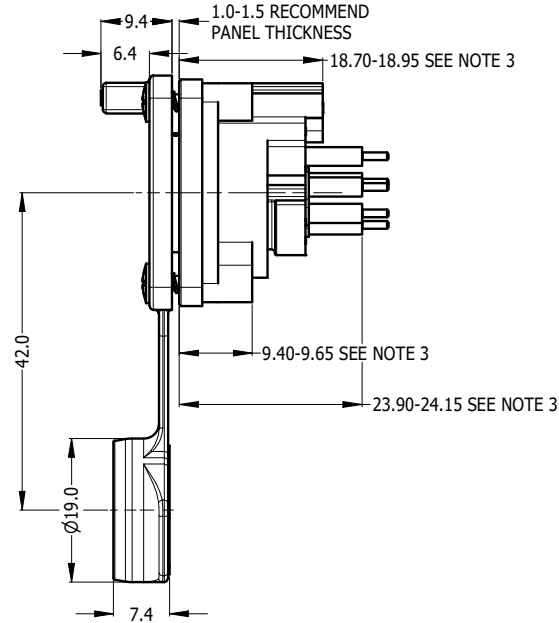
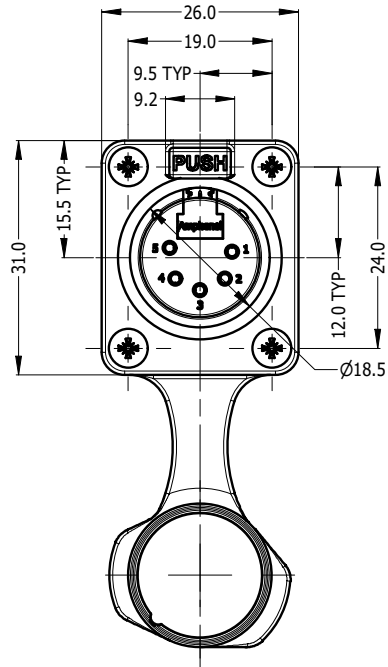

RECOMMEND MINIMUM MOUNTING PITCH

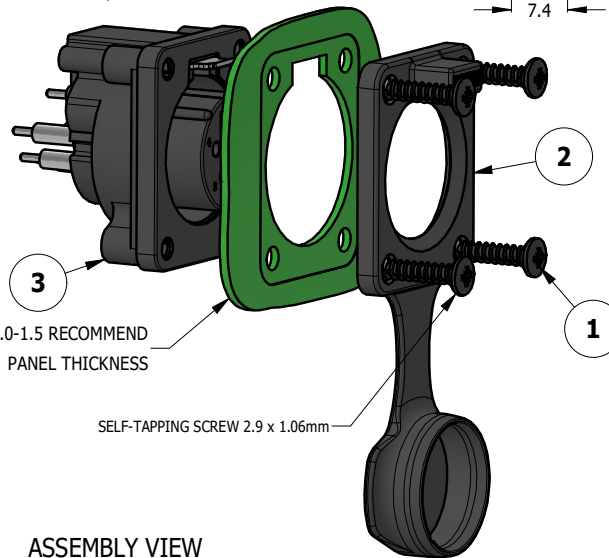
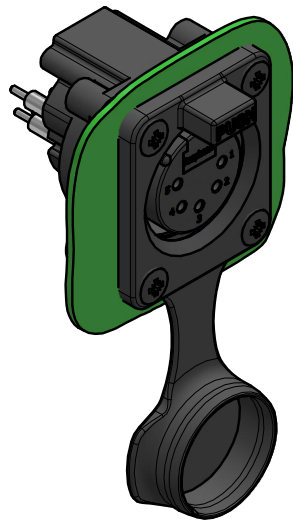

ASSEMBLY VIEW

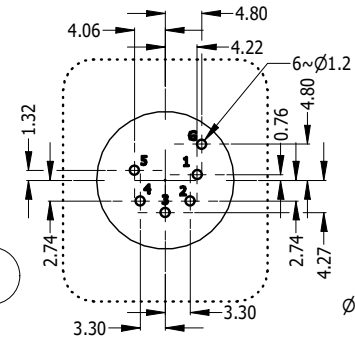

PCB LAYOUT  
CONNECTOR SIDE

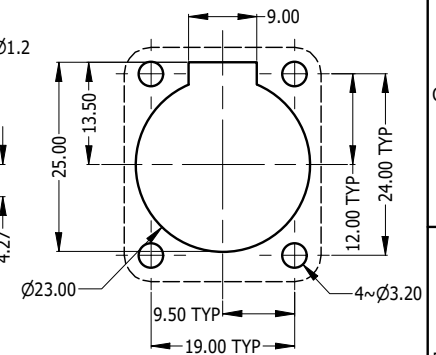

RECOMMEND PANEL CUT OUT

REVISION HISTORY				
REV	DESCRIPTION	DATE	BY	ECN
1	FIRST ISSUE	15-05-23	MH	----
2	CHANGE LATCHING MECHANISM	10-05-24	MH	9750

- NOTE:  
 1. MATING CONNECTOR SHELL TO HAVE MIN 1.6 SURFACE FINISH TO ACHIEVE IP RATING OF THIS CONNECTOR.  
 2. BLACK MOUNTING SCREW 52500011-430 x 4 PCS TO BE SUPPLIED WITH THE CONNECTOR, MAX TORQUE 0.5Nm.  
 3. DUE TO 0.4mm THICK RUBBER SEAL, THE DIM WILL VARY DEPENDING ON THE SCREWS TIGHTENING IN ASSEMBLY.

ITEM	PART NUMBER	DESCRIPTION	QTY
3	55011487-005/905	AXS5FHV WITHOUT RUBBER FLANGE - TIN/GOLD PLATED CONTACT	1
2	52730032-000	AXS OVERMOLDED RUBBER FLANGE BLACK	1
1	52500011-430	SELF TAPPING SCREW 2.9 x 1.06mm BLACK	4

UNLESS OTHERWISE SPECIFIED TOLERANCE TO BE	
LINEAR	ANGULAR
X ± 0.5	X' ± 1
X.X ± 0.2	X.X' ± 30'
X.XX ± 0.1	X.XX" ± 15"

BREAK ALL SHARP EDGES AND REMOVE ALL BURRS

DO NOT SCALE

DIMENSIONS IN MILLIMETRES

THIS DOCUMENT IS THE PROPERTY OF AMPHENOL AUSTRALIA PTY. LTD.  
 NO PART THEREOF MAY BE REPRODUCED AND USED WITHOUT THE PRIOR WRITTEN CONSENT OF THE OWNER

MATERIAL: <b>SEE COMPONENT</b>	DRN: M.H	DATE: 15-05-23
FINISH: <b>SEE COMPONENT</b>	CKD: M.H	DATE: 10-05-24
	APP'D: P.M	DATE: 10-05-24
	SCALE: <b>1:1</b>	SIZE: <b>A4</b>

**Amphenol** Amphenol Australia Pty.Ltd,  
 22 Industry Blvd, Carrum Downs, VIC 3201

TITLE: <b>AXS5FPV AXS PANEL MOUNT SERIES CUSTOMER DRAWING</b>	PART No. <b>SEE TABLE</b>
CAD FILE: 55011487805112	DRAWING No. <b>55011487-805-2</b>
	SHEET <b>2/2</b>